

9800FL SERIES PANIC BOLT

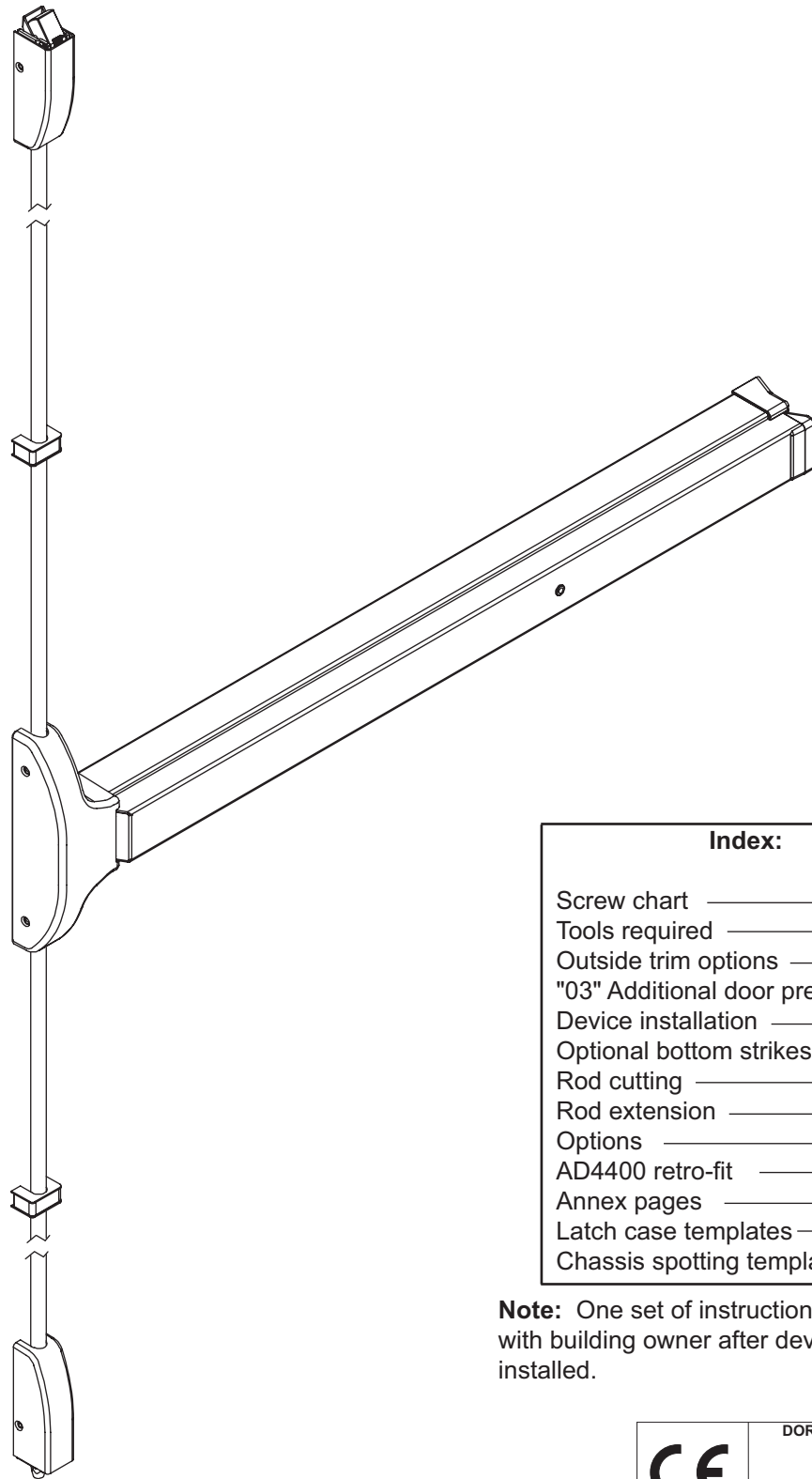

Index:	
Screw chart	2
Tools required	3
Outside trim options	4
"03" Additional door prep	5
Device installation	6-13
Optional bottom strikes	14
Rod cutting	15
Rod extension	15
Options	16-18
AD4400 retro-fit	19
Annex pages	20-21
Latch case templates	22-25
Chassis spotting template	26

Note: One set of instructions should be left with building owner after device has been installed.

EN 1125 CLASSIFICATION NUMBER FOR THIS PRODUCT

3	7	6	B	1	3	2	2	B	A
---	---	---	---	---	---	---	---	---	---

	DORMA Architectural Hardware 1003 West Broadway Steeleville, IL 62288 BS EN 1125 :2008
	European Norm Standard for Panic Exit Devices Operated By A Horizontal Bar.
	Product Classification 3,7,6,0,1,3,2,2,B,A
	Certification Body Ref Nr : 1121
9800FL AAA028 2011	

SCREW CHART

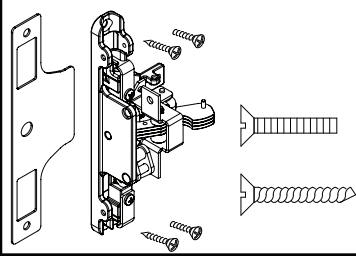
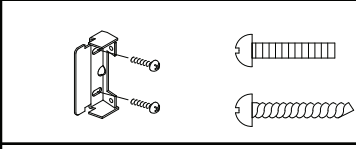
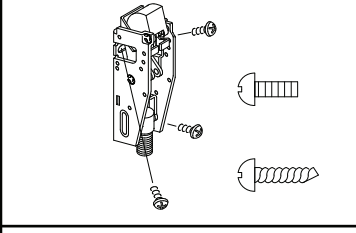
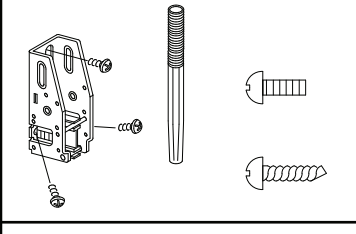
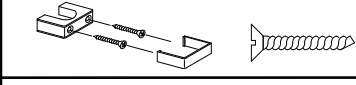
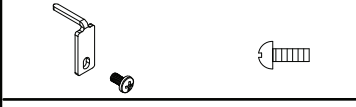
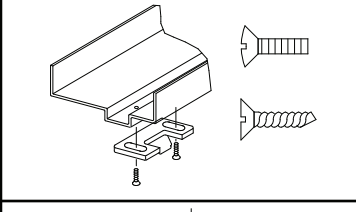
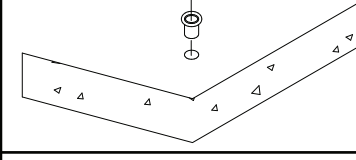
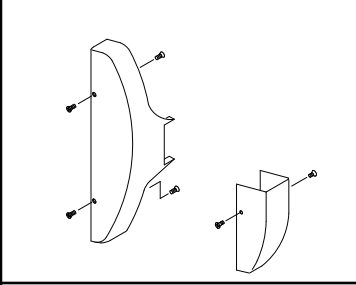
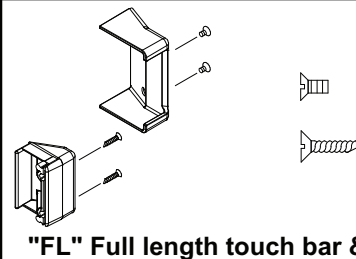
	<p>(2) M5 x 20 F.H.P.M.S. (Metal door metric version) _____ Chassis Mounting</p> <p>(2) 12-24 x 1 1/4" F.H.P.M.S. (Trim or Thru Bolts) _____ Chassis Mounting</p> <p>(2) #12 x 1 1/4" R.H.P.T.S. (Wood Door) _____ Chassis Mounting</p>
	<p>(2) M5 x 20 R.H.P.M.S. (Metal door metric version) _____ End Cap Bracket</p> <p>(2) 12-24 x 1" R.H.P.M.S. (Trim or Thru Bolts) _____ End Cap Bracket</p> <p>(2) #12 x 1 1/4" R.H.P.T.S. (Wood Door) _____ End Cap Bracket</p>
	<p>(3) M5 x 12 P.H.P.M.S. (Metal door metric version) _____ Latch To Door</p> <p>(2) 12 -24 x 19 R.H.P.M.S. (Metal or Thru Bolts) _____ Latch To Door</p> <p>(3) #12 x 25 R.H.P.T.S. (Wood Door) _____ Latch To Door</p>
	<p>(3) M5 x 12 P.H.P.M.S. (Metal door metric version) _____ Latch To Door</p> <p>(2) 12 -24 x 19 R.H.P.M.S. (Metal or Thru Bolts) _____ Latch To Door</p> <p>(3) #12 x 25 R.H.P.T.S. (Wood Door) _____ Latch To Door</p>
	<p>(4) #8 x 38 F.H.P.T.S. _____ Rod Guide Mounting</p>
	<p>(2) 8-32 x 13 R.H.P.M.S. _____ Rod Retaining Clip Mount</p>
	<p>(2) M5 O.H.P.M.S. (Metal) _____ #AD426 Keep Pack</p> <p>(2) #12 x 25 F.H.P.T.S. (Wood) _____ #AD426 Keep Pack</p>
	<p>_____ #AD439 Bottom Keep (Cement or Grout In Place)</p>
	<p>(10) 8-32 x 6 F.H.P.M.S. _____ Chassis Cover, End Cap & Latch Covers</p>
	<p>(2) 8-32 x 6 F.H.P.M.S. _____ End Cap Mounting</p> <p>(2) #10 x 25 F.H.P.T.S. _____ End Cover Mounting</p>

"FL" Full length touch bar & rail series.

HANDING OF DOOR

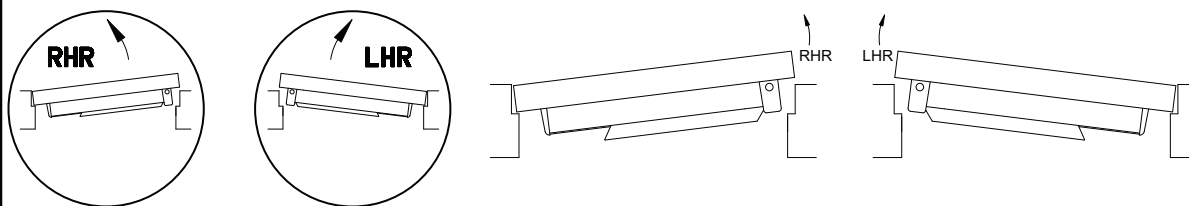

Read the entire instruction sheet prior to installation.
Before Installing Hardware:

1. Verify door width, handing and product with carton label for correct exit device and length. (See Step 6)
2. For hand reversal of chassis see page 7, for outside lever trim see page (4).
3. For less bottom rod device, delete bottom latch installation steps.

Note: Less bottom rod device is not recommended where security is a primary concern.

Note: If device is to be installed over glass lite panels, shim kit may be required, order GK9200.

TYPICAL DEVICE FIXING

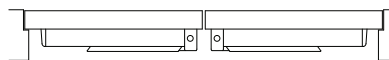
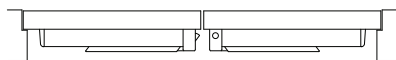
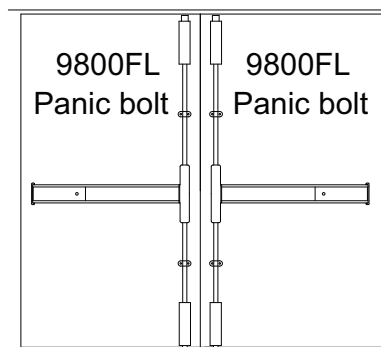
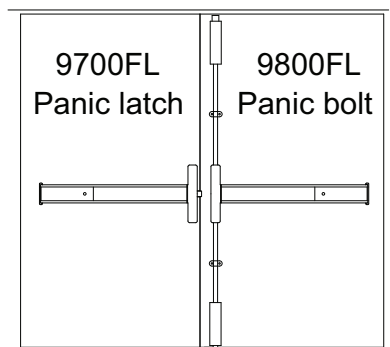

SPECIAL TOOLS FOR FIXING

Centre Punch
M5 - Tap, M6 - Tap
Drill bits: 3.8mm, 4.2mm, 10mm, 13mm, 25mm & 38mm
5/32" Allen wrench for lever trim.
Cross point screw driver
Hack saw

TYPICAL OUTSIDE TRIM INSTRUCTIONS

Note: When used with narrow stiles, consult door manufacturer for compatibility.



LHRB TRIM SHOWN RHRB OPPOSITE

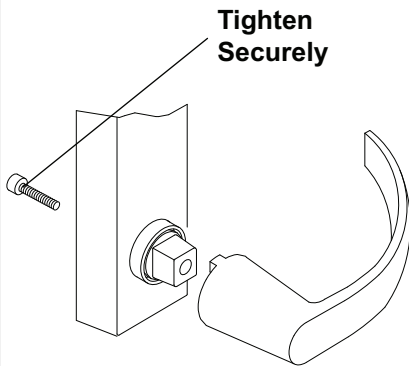
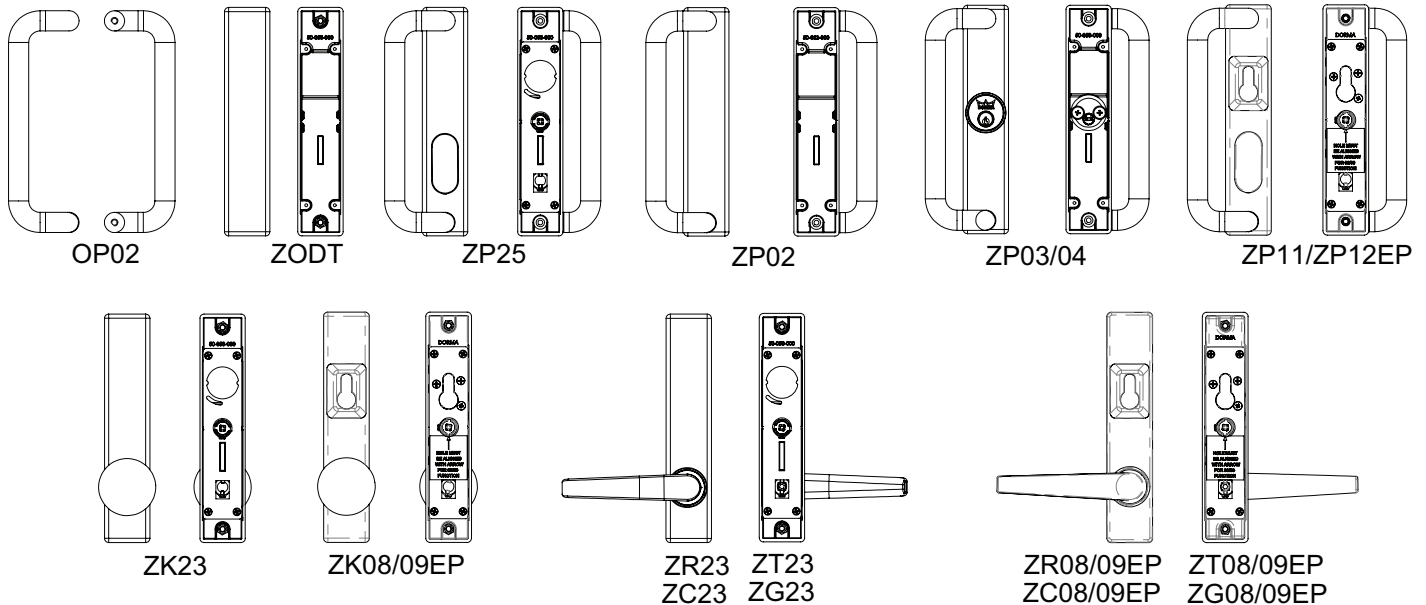

IMPORTANT

Note: All lever handles except for "clutch" are shipped unattached. To install; **Place handle in desired position and attach with allen screw located in back of trim plate. 5/32"** Allen wrench required.
To change hand on "clutch" trim rotate and "break" lever around to desired hand.

All trims are free wheeling.
(Handle will rotate when locked.)

Fixing of "EP" cylinder

Insert "EP" cylinder into adapter, secure with set screw supplied with cylinder. Insert adapter/cylinder assembly thru trim and secure assembly with (2) 8-32 screws as shown. For "09" function (key only removable when locked) insert additional 8-32 screw as shown.

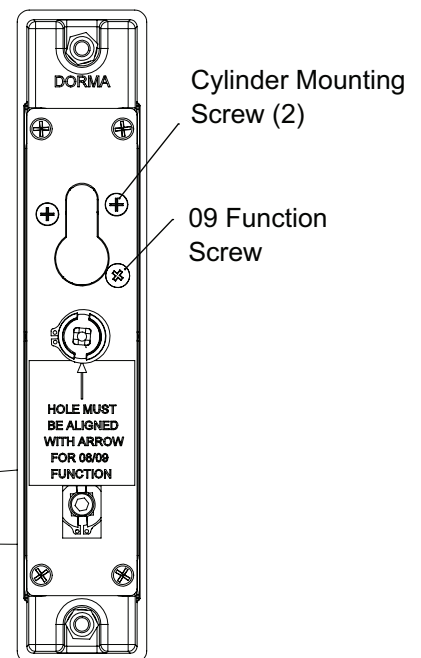
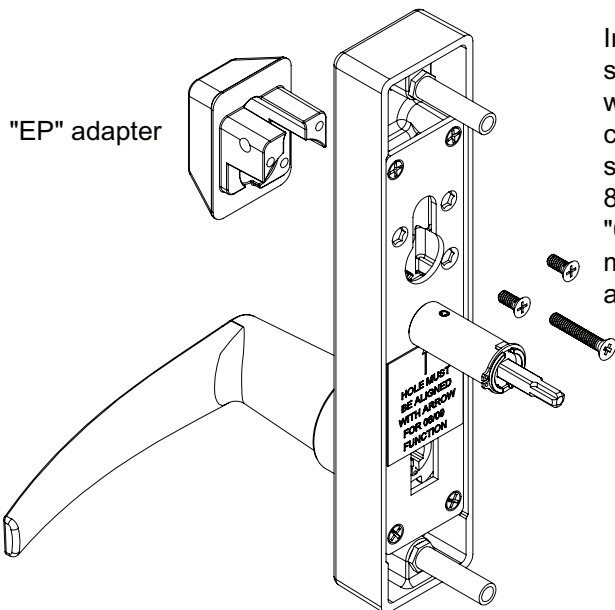

ADDITIONAL DOOR PREP REQUIREMENTS

9800FL

Surface panic bolt

RHR Shown

LHR Opposite

Required for "03" & "04" function on device
with cylinder only and no trim.

(NOT TO SCALE)

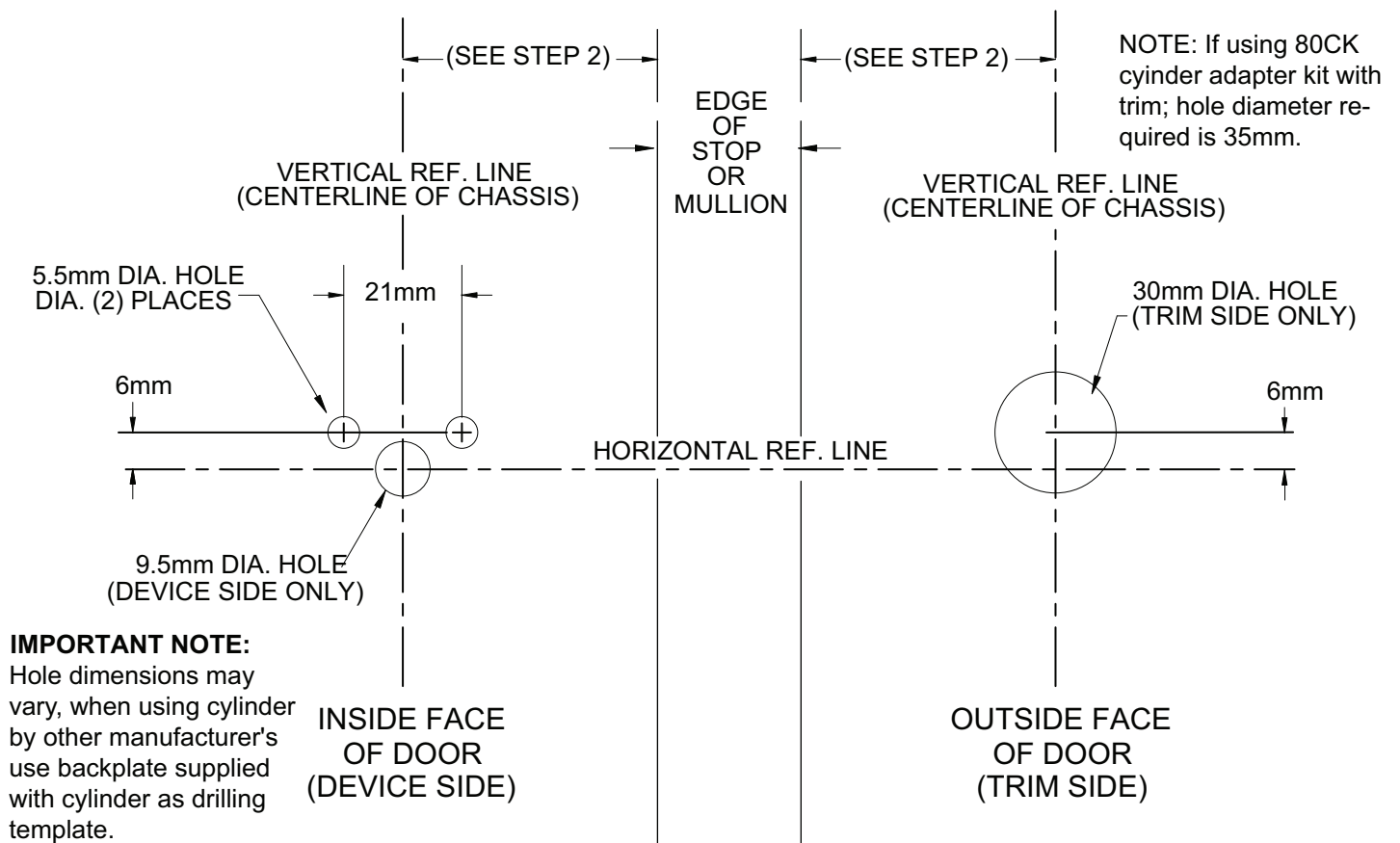

1 With door lying on saw horses, open box, layout all parts and verify prior to starting installation. See page (2) two for parts.

Note: If this is a retro-fit from current AD4400 see page prior to proceeding.

2 Door preparation

Chassis vertical ref. line

Chassis template located at rear of booklet. Cut and tape in place. Lay out horizontal and vertical reference lines.

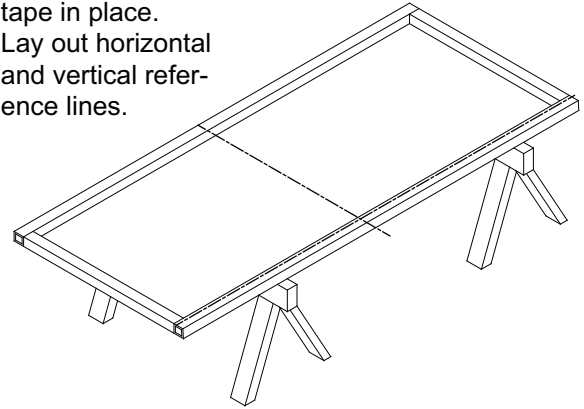
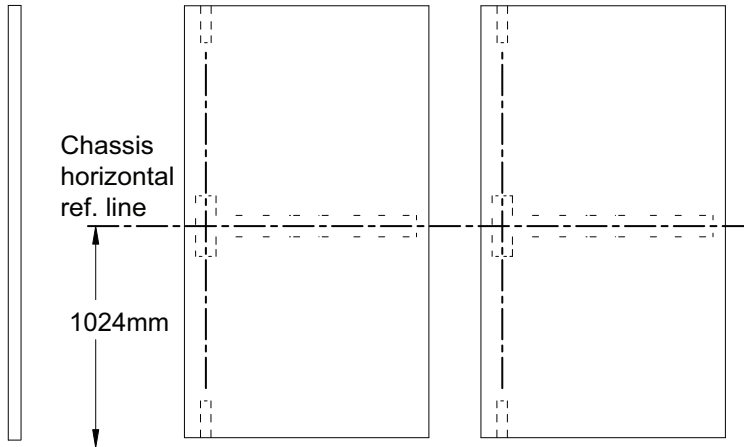

Finished floor, if using threshold measure from top of threshold.

Backset or vertical reference is measured from outer edge of door as shown. Minimum stile is less glass stop.

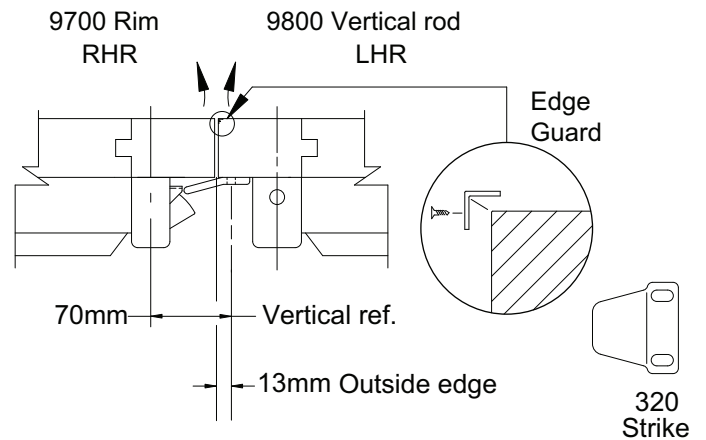
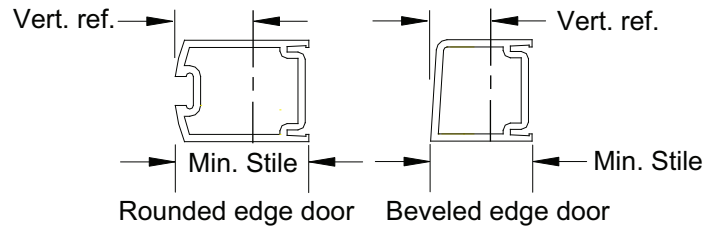
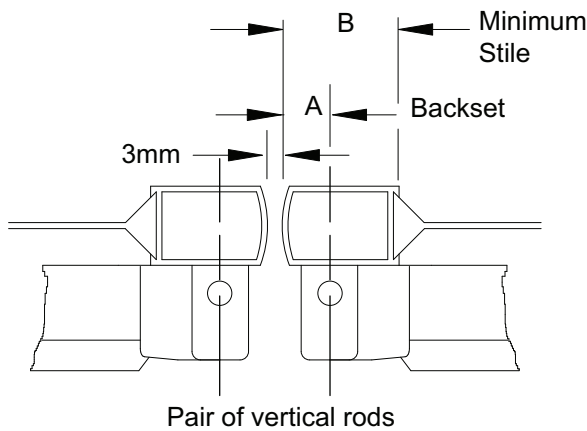

Type of installation	Minimum vertical ref. of chassis	Minimum Stile	
		Pull only	"Z" trim
Single door 13mm blade stop	35mm	51mm	56mm
Pairs and double egress	32mm	41mm	54mm
Paired with 9700 rim	41mm	56mm	64mm

3 Hang door(s) in opening, ensure they are square and plumb.

4 If not done layout device on door using drilling template T9800 located at rear of booklet.
For additional templates contact DORMA at 1-800-523-8483 or www.dorma-usa.com

Refer to carton label for model and trim number prior to drilling.
Prepare mounting holes and cut-outs per template.

VERTICAL REF. LINE
(See Backsets on page 6.)

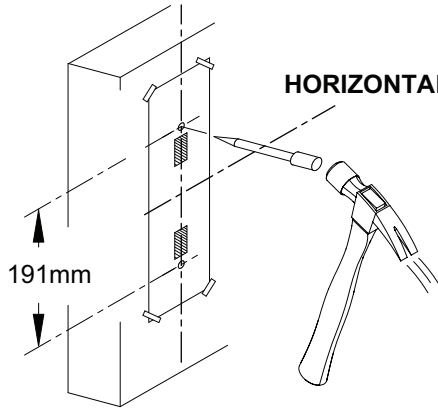

HORIZONTAL REF. LINE

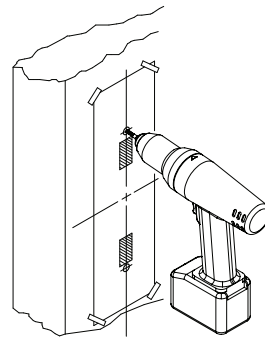

Verify all holes
prior to drilling.

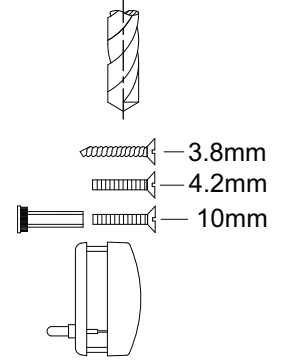

5 Hand reversal of chassis (if required). Follow steps in alphabetical sequence.

DISASSEMBLE
RHR
(Right Hand Reverse)

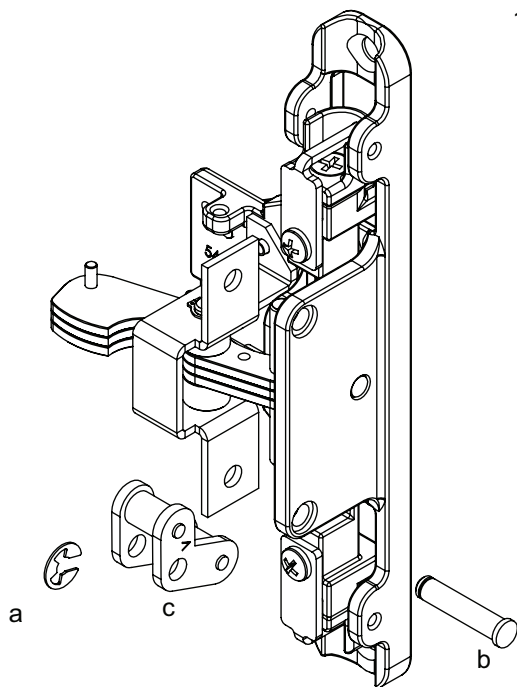

Rotate chassis
180 Degrees
d

REASSEMBLE
LHR
(Left Hand Reverse)

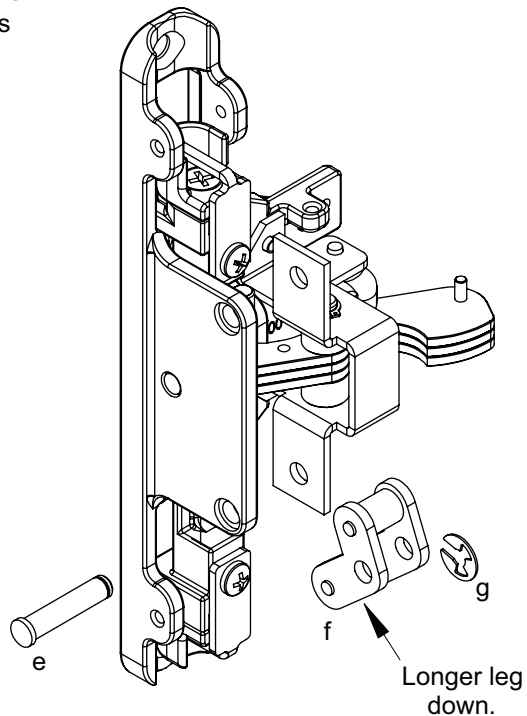

6 Prepare to install touch bar and rail on door.

NOTE: All dimensions are based on 13mm stop height; Verify strikes, stile width, any trim and stop height prior to making any cuts. If cutting is required follow instructions below.

Size AA:

Fits 1220mm door opening without cutting.
Can be cut to fit a 838mm minimum door opening.

Size BB:

Fits 915mm door opening without cutting.
Can be cut to fit a 686mm minimum door opening.

Size CC:

Fits 915 door opening with out cutting.
Using a shorter touch pad then the standard "BB" size allows it to be cut to 610 door opening.

Note: Models with prefix options such as "ES", "DE" etc. may not be cut down to minimums shown to left. Consult factory or catalog for details.

Verify device length with box label; "AA", "BB" or "CC", ie. 9800FL BB

Example:

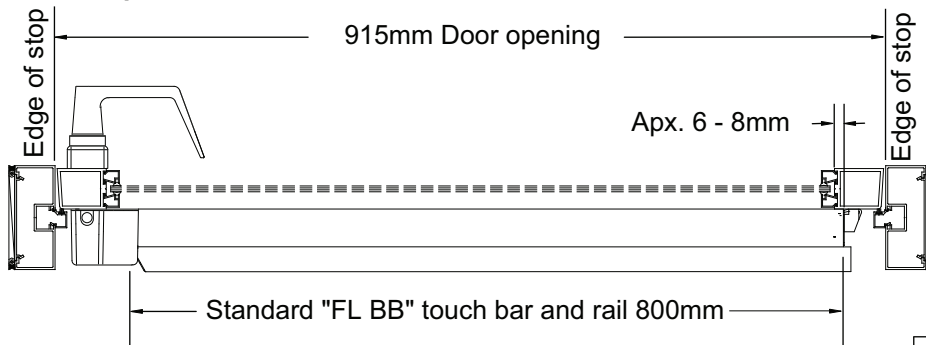

Note: If door opening width is less or stops are different, then standard touch bar will have to be cut down. ie: door opening width 863mm subtract 51mm from rear of rail, depress touch bar as shown, tape and cut to length as shown. Touch bar should be approximately 5mm longer then rail once it is released to upward position.

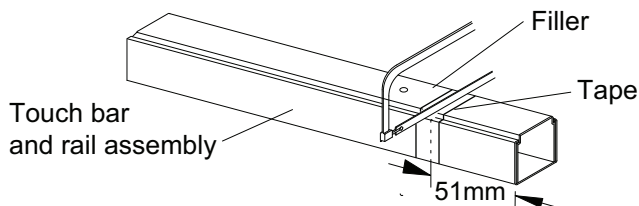

IMPORTANT

Use caution when cutting touchbar and rail to size on models with "ES", "MS", "LM" or "DWA" prefix options. These units contain internal wiring. For models with prefix options "BPA", BPAR" or "DE" remove filler containing electronics before cutting.

7 Secure chassis to door as shown.

Metal - (2) M5 x 20 F.H.P.M.S.
Wood - (2) #12 x 32 F.H.P.T.S.
(For other options; trim, thru bolts, etc. see below.)

For 89mm stiles or less on aluminum doors, place shim under chassis prior to mounting on door. (Finished side to outside face.)

Optional mounting

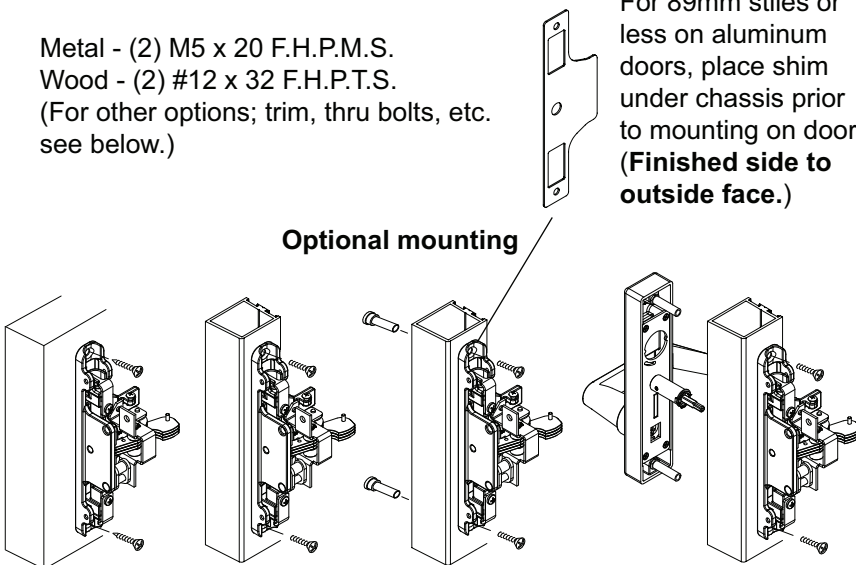

8 Install "FL" touch bar and rail assembly and end cap to door.

Remove two 8-32 screws from chassis, slide touch bar and rail assembly under rear of chassis. **Note: If device has prefix "ES" ensure that pins in lever bolt align with slots in actuator located inside nose of touch bar.** See instruction sheet IES-7 packed with device. Install (2) two 8-32 x 10mm P.H.P.M.S. to secure touchbar to chassis.

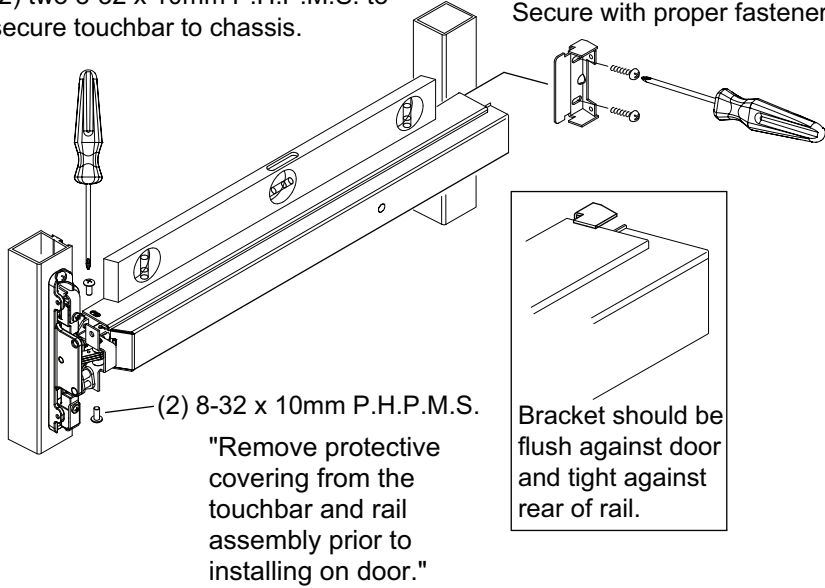

NOTE: If carton label list prefix; "ES", "MS", "LM", "BPA", "BPAR", "DWA", "LM/MS/BP" or "CD" prefix see Options pages at rear.

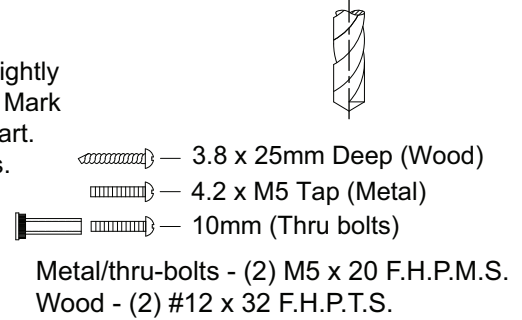

For the following models prefixes: "ES", "MS", "LM" or "DWA" drill an additional 13mm diameter hole as shown. See options pages at rear for additional information.

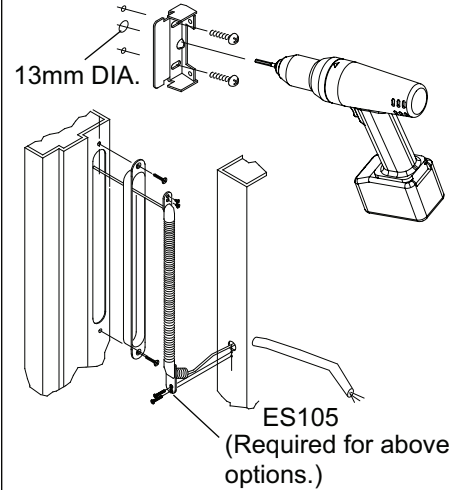

9 Prop door open and layout and prep top and bottom latch case locations. Templates located at rear of booklet, tear out, cut and tape to door as shown, mark and drill per chart.

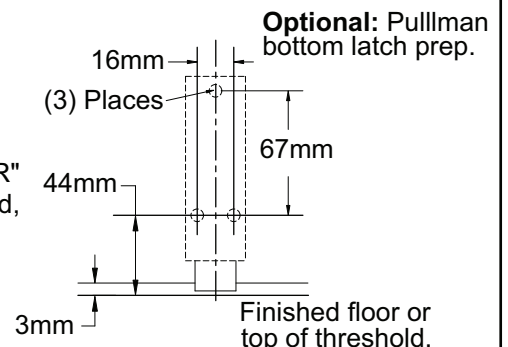
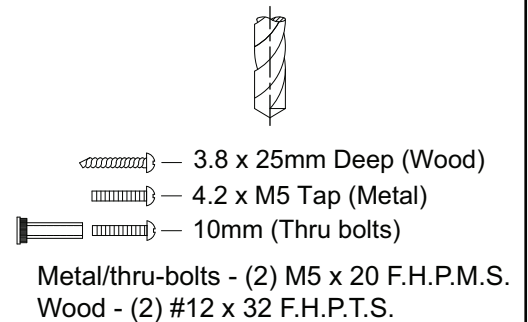
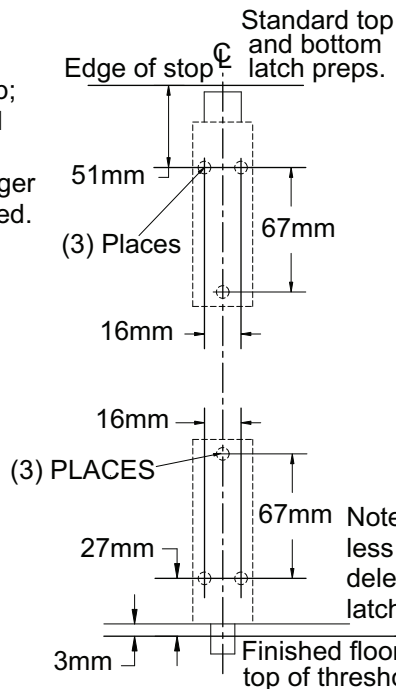
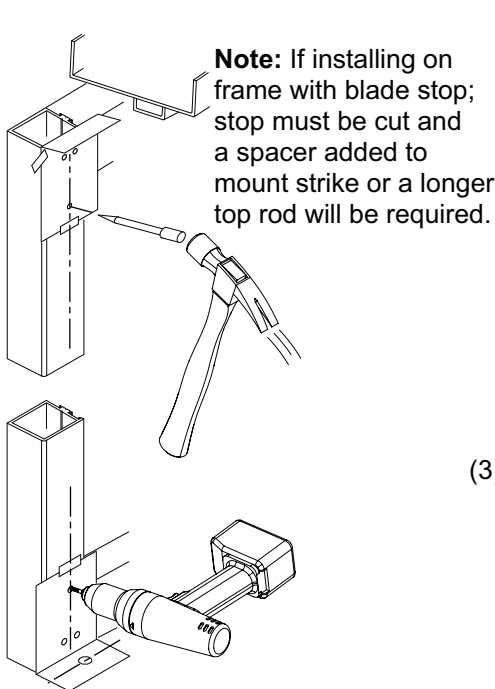

10 Install top and bottom latch case assemblies.

 —No. 12 x 25 R.H.P.T.S. (Wood)

 —M5 R.H.P.M.S. (Metal)

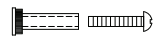
 —M5 R.H.P. M.S. (Thru bolts)

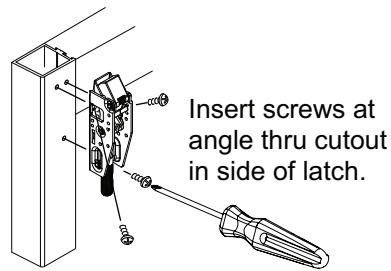

Insert screws at angle thru cutout in side of latch.

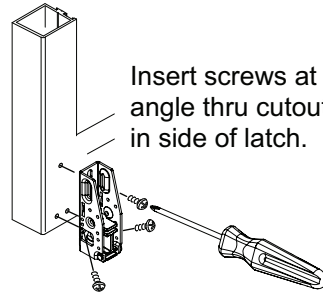

Insert screws at angle thru cutout in side of latch.

11 Install top rod and adjust top latch.

Note: Same for either standard or FL series.

Rods shipped cut to length for 2134mm door opening. Optional 2438mm door opening available, (must be requested at time of ordering). For doors over 2438mm and up to 3048mm request "ETR" package at time of ordering. For top rod length other than "standard" see chart below. Order 2438mm option and cut to length.

Depress tripping lever and ensure that top latch is fully extended and in dead locked position. **Bolt should not be able to be depressed.** Bellcrank of chassis should be completely down in home position.

Thread top rod onto adjusting bolt until hole in bottom of rod aligns with hole in rear of top portion of bellcrank. **Insert leg of retaining plate through hole in rod and hole in bellcrank, install 8-32 x 13mm screw and tighten securely.**

2134mm
Standard Top Rod
895mm

2438mm
Optional Top Rod
1200mm

610mm

"ETR"
Extended top
rod extension.
"Do not cut."

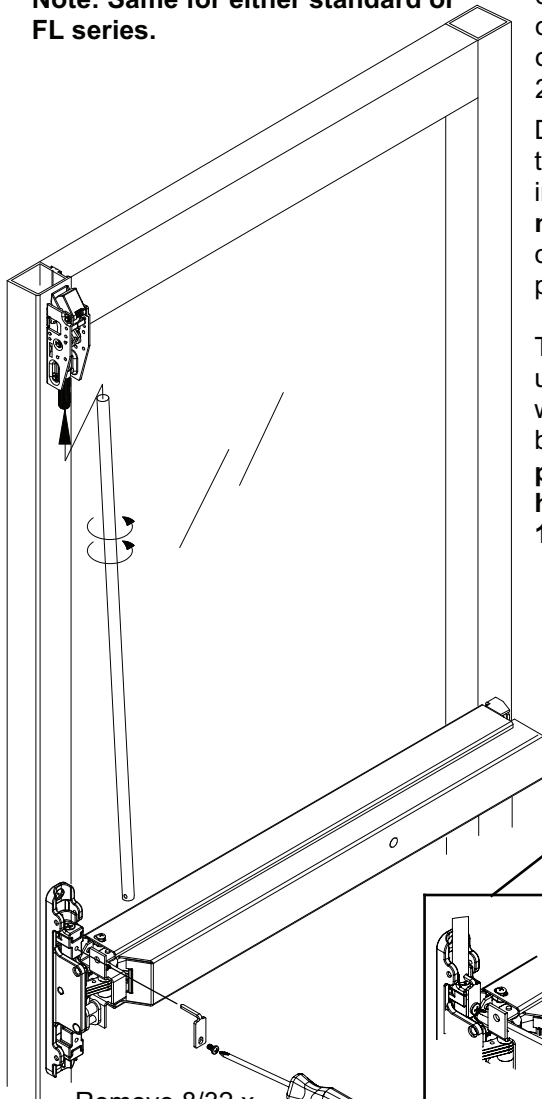

Remove 8/32 x 13mm phillips head screw from retaining plate as shown.

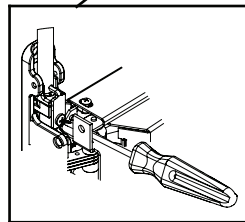

NOTE:

If horizontal reference line is moved from the recommended mounting height, new rods may have to be ordered.

If cutting is required "Do Not Cut Threaded End". (See Chart)

Use supplied drill jig and 4.3mm drill bit if new hole is required.

DOOR HEIGHT	TOP ROD LENGTH
2032mm	794mm
2083mm	845mm
2134mm	895mm
2184mm	946mm
2235mm	997mm
2286mm	1048mm
2337mm	1099mm
2388mm	1149mm
2438mm	1200mm

12 Check for proper function of device and top latch assembly.

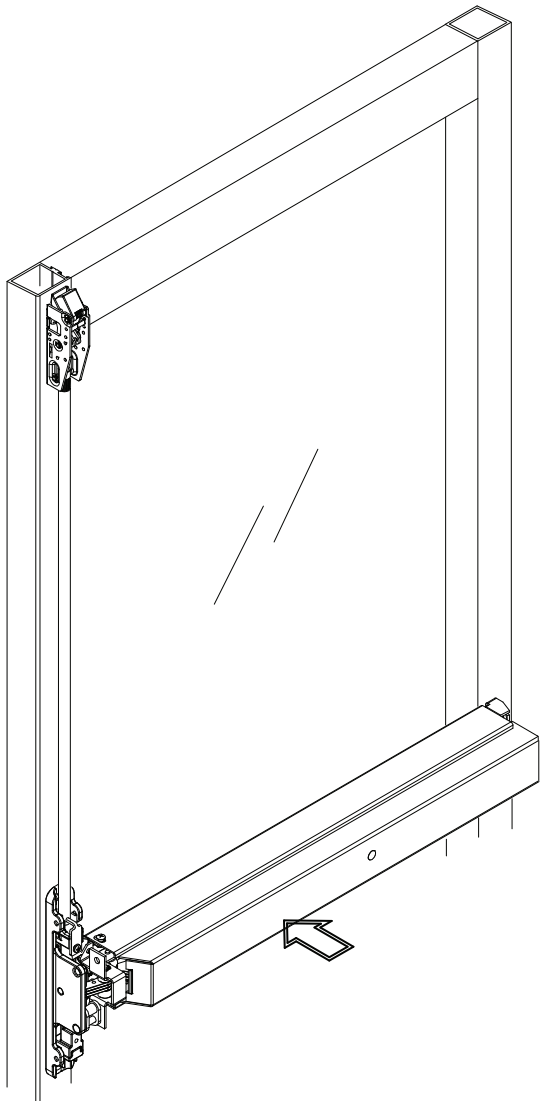

Depress touch bar slowly, top latch bolt should retract fully. Hold bar depressed, push in and hold top tripping lever. Latch bolt should be flush or slightly depress in top latch case.



If this is found, release touch bar and tripping lever top latch bolt should remain captured by tripping lever.

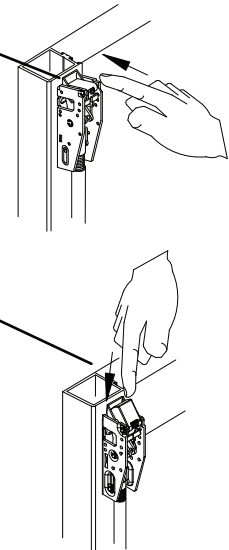

Push in on tripping lever and release top latch bolt, bellcrank should drop completely down and top latch should be fully extended and dead locked. **(You should not be able to push the bolt in.)**

If top bolt does not retract fully or can be pushed in, adjustment of top rod is required: Remove 8-32 screw and retaining plate; rotate rod left (clock-wise) to lengthen, half turns at a time. Re-install retaining plate and screw; check for dead lock after each turn.



13 Install top strike. See spotting templates located in rear of booklet if not already done. Check for proper alignment and operation with top latch after installation.

-  #10 x 25 F.H.P.T.S. (Wood)
-  M5 O.H.P.M.S. (Metal)

-  #10 x 25 R.H.P.T.S. (Wood)
-  M5 R.H.P.M.S. (Metal)
-  M5 R.H.P.M.S. (Thrubolts)

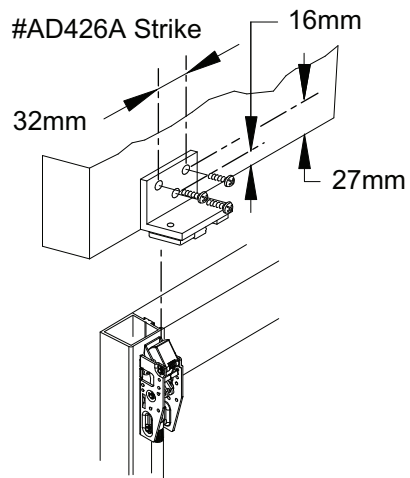
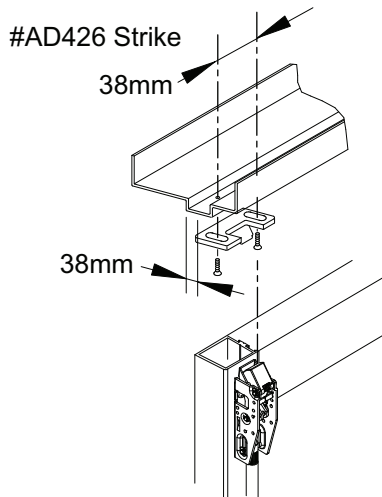

14 Installation of bottom slide bolt or latch assembly.

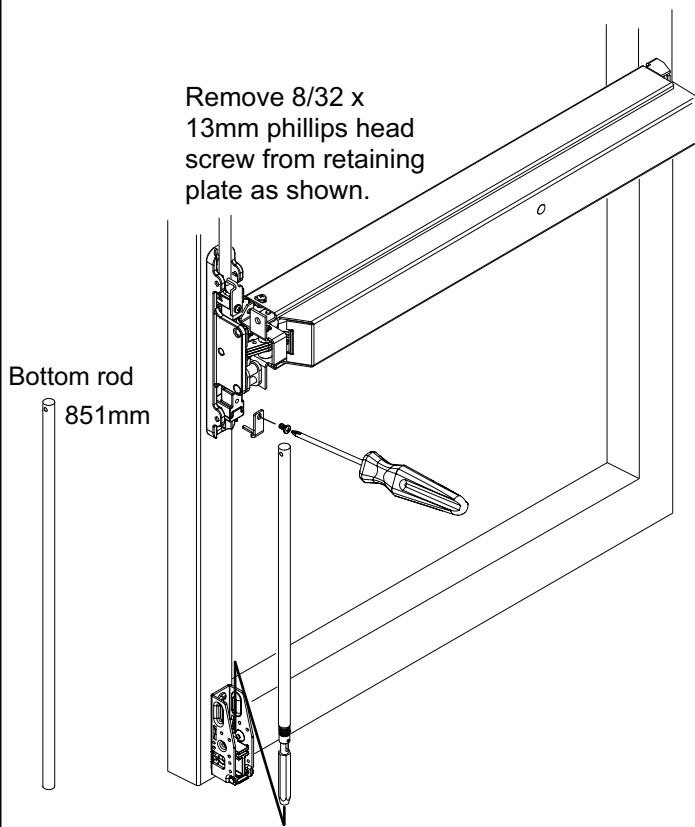

NOTE:
If horizontal reference line is moved from the recommended mounting height, new rods may have to be ordered.

If cutting is required "Do Not Cut Threaded End".

Use supplied drill jig and 4.3mm drill bit if new hole is required.

Thread bottom rod approximately 1/2 way on to slide bolt assembly.

With bell crank down and top latch fully extended and dead locked.

Insert rod and slide bolt assembly in to bottom latch bracket as shown, rotate rod until hole in rod aligns with hole in bell crank. Insert retaining clip and secure with 8-32 x 13mm screw.

Check to see that there is approximately 16mm of bolt hanging down and that bolt moves up and down freely in latch case.

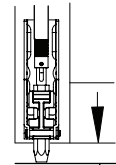
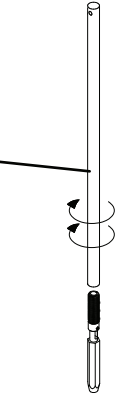

Aprox. 16mm

With bell crank down and top latch fully extended and dead locked.

For optional pullman latch: Thread rod approximately 1/2 way on to adjusting bolt, tilt rod upward, rotate rod clock-wise to shorten, counter clock-wise lengthen until hole in rod aligns with hole in bell crank. Bolt should be dead locked when down just as top bolt. Adjust rod until dead lock is achieved.

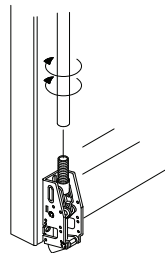

15 Installation of standard bottom strike. For additional strike installations see templates in rear of booklet.

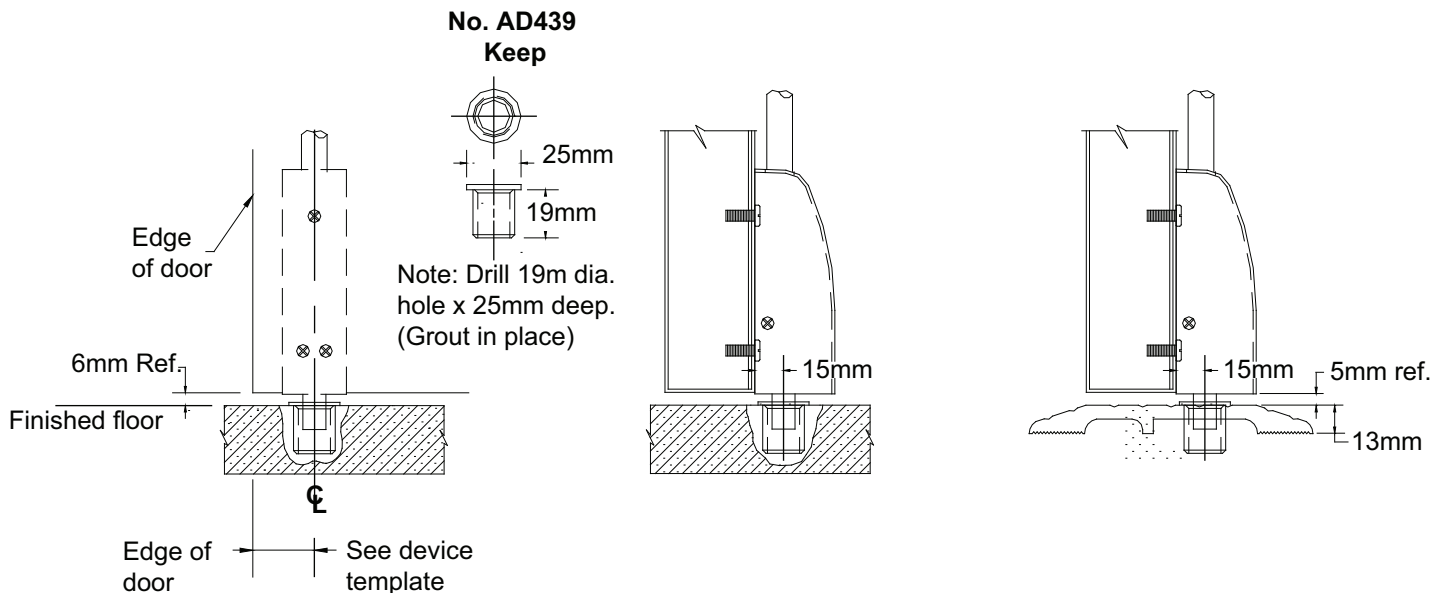

16 Verification of rod adjustments.

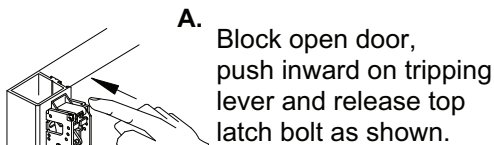

A. Block open door, push inward on tripping lever and release top latch bolt as shown.

Top latch should be fully extend and dead latched as shown and bell crank should drop completely down.

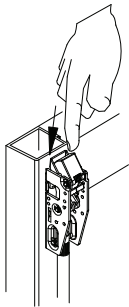
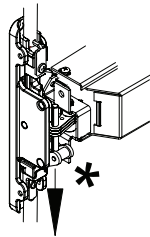

B. Check for dead lock by attempting to push downward on top latch bolt (**it should not push in**). "Only" if it can be pushed in adjust rods per step below.

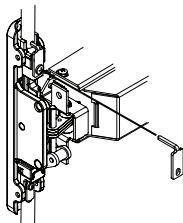

C. To adjust: Remove 8-32 screw, remove retaining plate, rotate top rod right (counter clock-wise) to shorten and left (clock-wise) to lengthen. **Rotate half turns at time, re-install retaining plate and screw after each turn and check for dead lock of top latch bolt.**

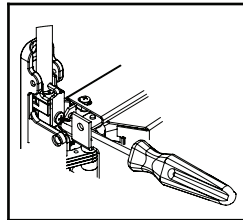

Flush

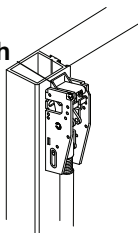

D. Depress and hold touch bar. **Push in on tripping lever and hold depressed**, check position of top latch bolt. It should be flush to slightly depressed in top latch bracket.

E. Release tripping lever and touch bar, top latch should remain in retracted position

Slide bolt clears strike

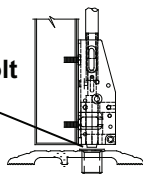

F. With top latch held retracted by tripping lever, check bottom slide bolt to ensure it clears the strike, threshold, and floor by unblocking and swinging door.

If adjustment is required; follow same steps as in step C above for top rod until proper clearance is achieved.

G. Close door and check that top and bottom latch bolts align and engage in top and bottom strikes.

H. After rods are fully adjusted ensure that top and bottom rod retaining plate screws are tight.

I. Check device operation by opening and closing door several times from **inside**. Check and operate outside trim if installed.

Repeat rod adjustment procedure if:

Top latch is not held retracted
Bottom slide bolt does not clear strike or floor.
Latches do not work properly with outside trim

J. Install rod guides, end cap, center case and latch covers.

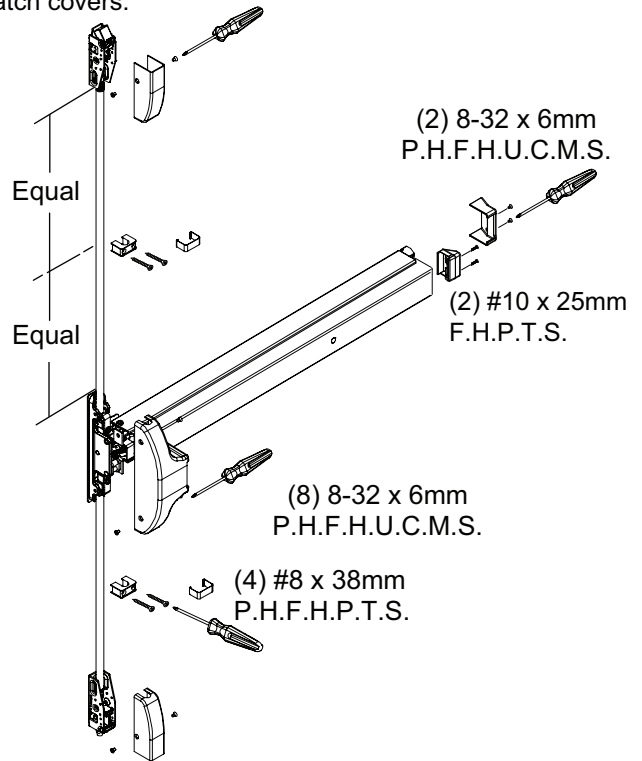

K. Standard hex key dogging, depress touch bar insert supplied hex key and rotate clock wise to dog and counter clock wise to undog.

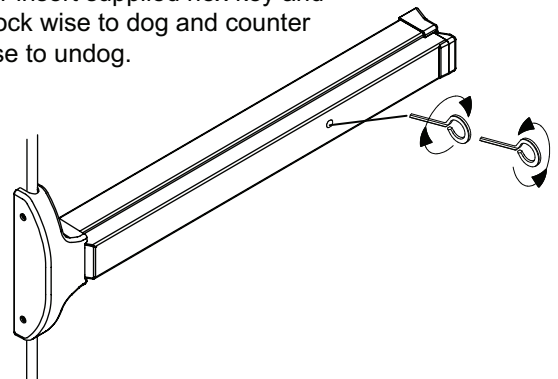

OPTIONAL: BOTTOM KEEP PREPARATION

#AD416 Keep

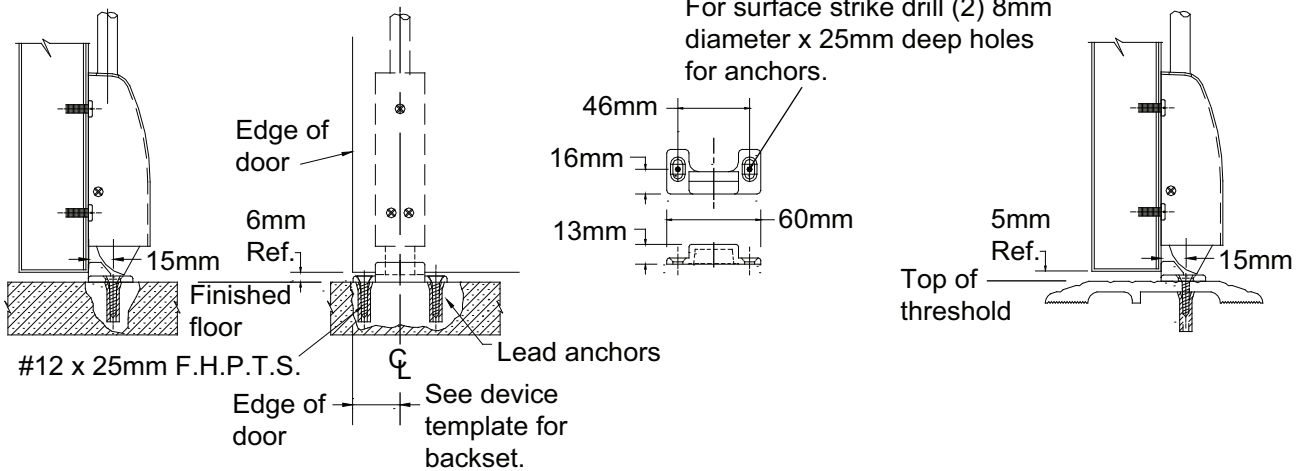

#AD431 Keep

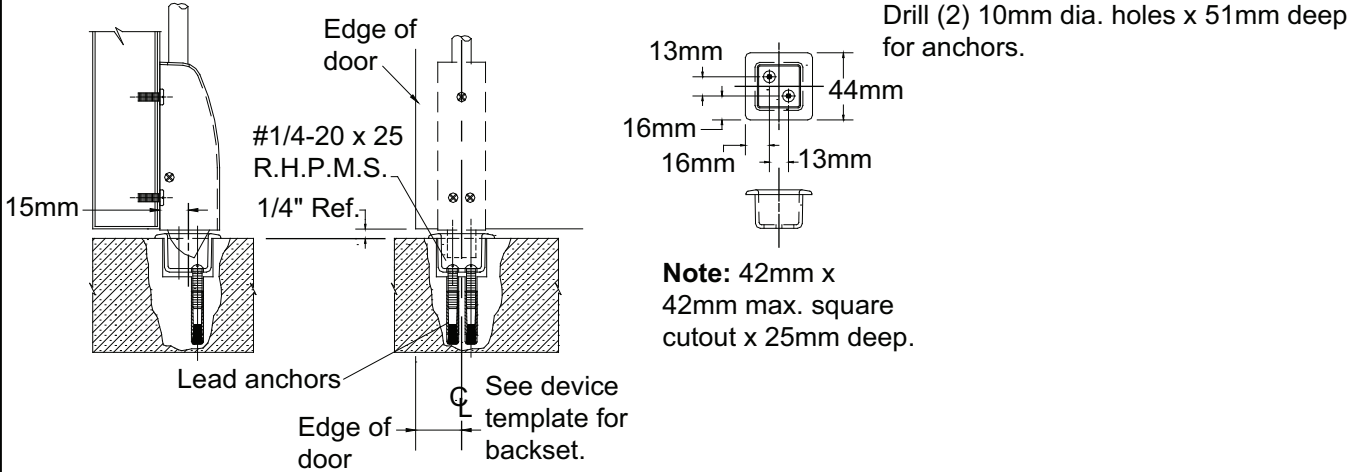

#AD340 Strike

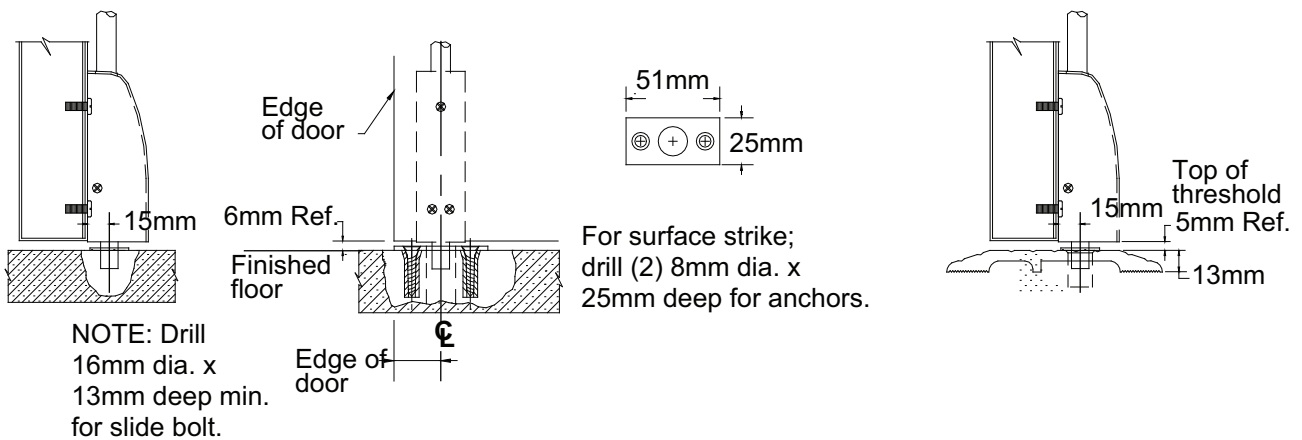

ROD CUTTING

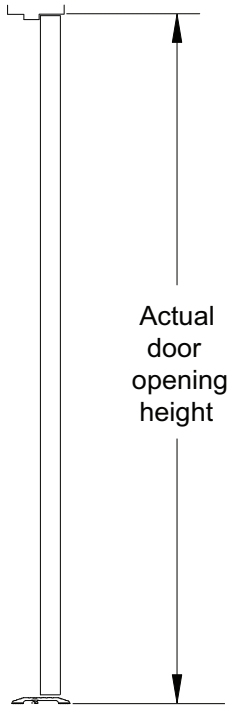

NOTE: Rods shipped standard from factory for 2134mm seven foot door opening. Optional rod pack for 2438mm eight foot openings available **"must be noted at time of order"**.

For doors under 2134mm seven foot subtract difference from bottom of top rod, cut per details and redrill hole for retaining plate.

For doors over 2134mm seven foot but under 2743mm nine foot a 610mm two foot rod extension "ETR" is available. Thread top rod and rod extension together, deduct difference, cut from bottom of top rod and redrill hole for retaining plate. **"Do not cut rod extension"**.

For doors over 2438mm eight foot but under 3048mm ten foot the 610mm two foot rod extension "ETR" is added to the 2438mm eight foot rod pack. Thread top rod and rod extension together, deduct difference, cut from bottom of top rod and redrill hole for retaining plate. **"Do not cut rod extension"**.

NOTE:
If horizontal reference line is moved from the recommended 1024mm height, new rods will have to be ordered.

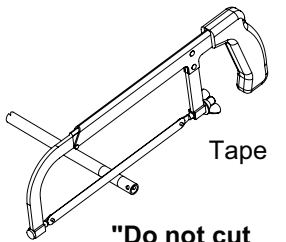

"Do not cut threaded end"

Tape

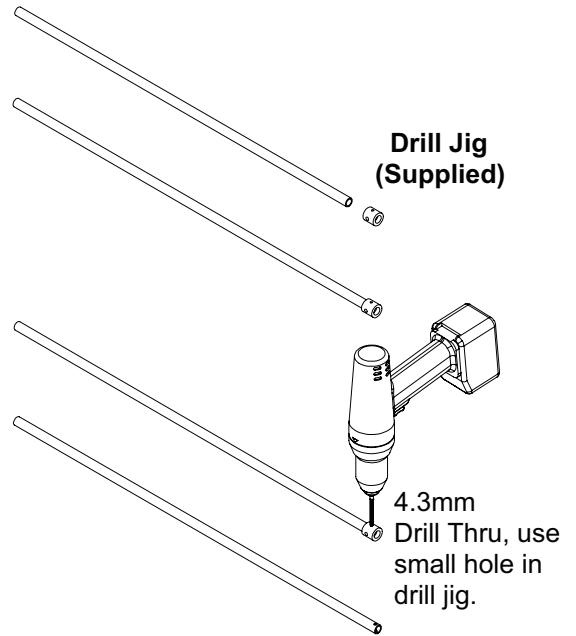

Drill Jig (Supplied)

4.3mm Drill Thru, use small hole in drill jig.

INSTALLING ROD EXTENSION



For "ETR" (Extended Top Rod) devices.
***Do not cut extension piece!**

Connecting link

Thread rods together securely. "Loc-tite may be used for added security".

Standard top rod

OPTIONS: Cylinder dogging

Cylinder specifications and cams;

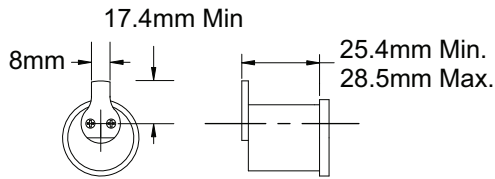

Note: When using IC core cylinders, ensure that cam is in proper position prior to installing the new core.

Useable Cams

Arrow	001	Ilco/Unican	SC1
Assa	Std. (Yale)	Lori	SC1 4200-82-2002 Std.
Best	C136	Sargent	13-0664 or 13-0660
Corbin	A02	Schlage	001
Falcon	12667-3	Yale	2160

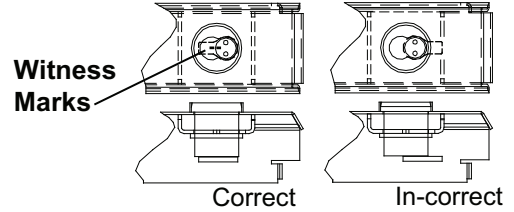

Cylinder dogging option on full length touch bar and rail; (See cam specifications above.)

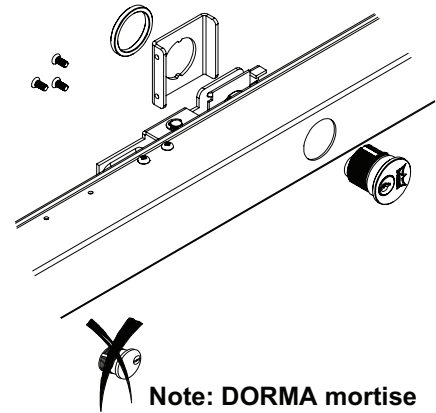
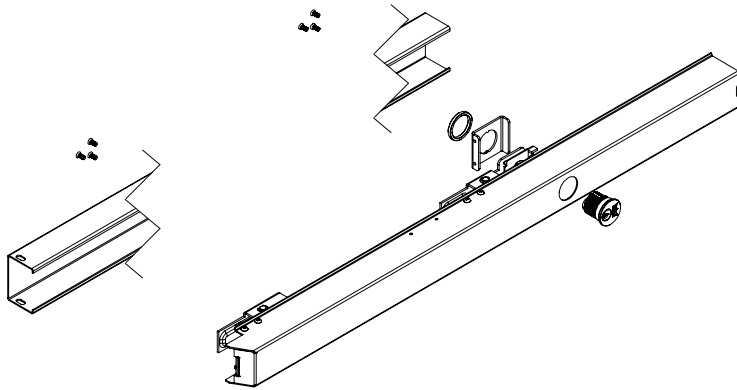

Note: DORMA mortise cylinder supplied. To use other manufacture cylinders, "L" less cylinder is available.

To change cylinder:

1. Remove end cap, end cover & end cap mounting bracket.
2. Remove cover from chassis and two chassis to touch bar mounting screws.
3. Remove (6) touch bar to rail mounting screw from underside of rail.
4. Flip rear arm assembly outward from underside of touch bar.
5. Remove cylinder nut on underside of touch bar.
6. Remove cylinder and mounting plate.
6. Insert new cylinder facing as shown in detail.
7. Install mounting bracket and cylinder nut.
8. Flip rear arm assembly back under touch bar.
9. Re-install touch bar to rail with (6) screws.
10. Install touch bar & rail back on to chassis with (2) screws.
11. Re-install end cap mounting bracket.
12. Re-install end cap, end cover & chassis cover.



Option: "LM" Latch monitor; monitors movement of latch bolt with or without depressing of touch bar. May be wired either normally open or normally closed.

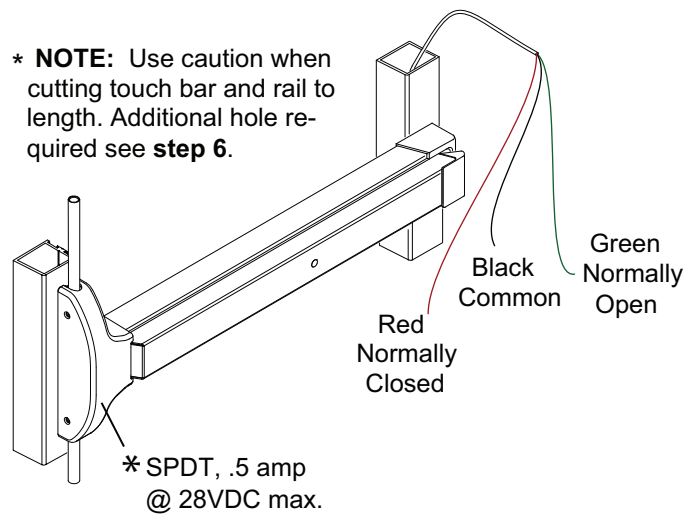

"BPA", "BPAR" & DWA (ALARM) Options; "BPA" Battery powered alarm, sounds continuous until reset. "BPAR" alarm sounds for 4 minutes then will automatically reset. **Alarm mode set at factory.**

Note: On the 9000"FL" version caution must be used when cutting touch bar and rail to length due to the wires running inside of the assembly. A standard **DORMA** cylinder is supplied on both units, to change to a customer supplied cylinder follow steps under "**cylinder dogging**". Refer to additional instruction sheet packed with device for operational instructions etc.

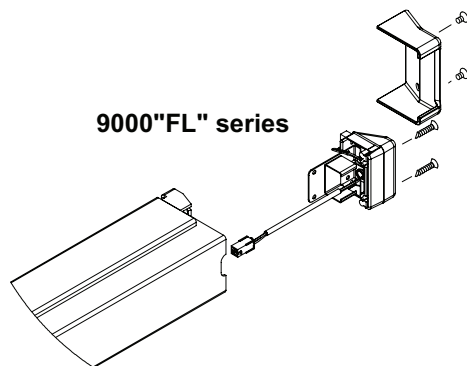

To change battery:

1. Prop open door.
2. Remove (2) end cover mounting screws.
3. Remove (2) end cap screws.
4. Remove end cap & replace battery.
5. Re-install in reverse order.

Size AA:

Fits 1220mm door opening without cutting.
Can be cut to fit a 851mm minimum door opening.

Size BB:

Fits 915mm door opening without cutting.
Can be cut to fit a 699mm minimum door opening.

Size CC:

Fits 915mm door opening with out cutting.
Using a shorter touch pad then the standard "B" size allows it to be cut to 622mm door opening.

"DWA" OPTION:
Battery Eliminator

White

Green
(Non-polarized)

Connected to outside power source; 12-24V AC/DC supply. ie: Dorma ES-100 etc.
Contact Dorma **1-800-523-8483** for other supplies available.

OPTIONS

Option: "ES" Electric latch retraction: Electrically retracts latch bolt(s) when energized by power supply.

Electrically retracts latchbolt(s)
when energized by power supply.

**REQUIRES DORMA ADPS501 POWER SUPPLY
AND ES105 POWER TRANSFER.**

ADPS501 Will operate (2) "ES" 9800 exit devices,
but is capable of powering (2) additional devices
by installing the optional "ES-2" card.

***NOTE:** Use caution when
cutting touch bar and rail to
length. Requires additional
hole see **step 6**.

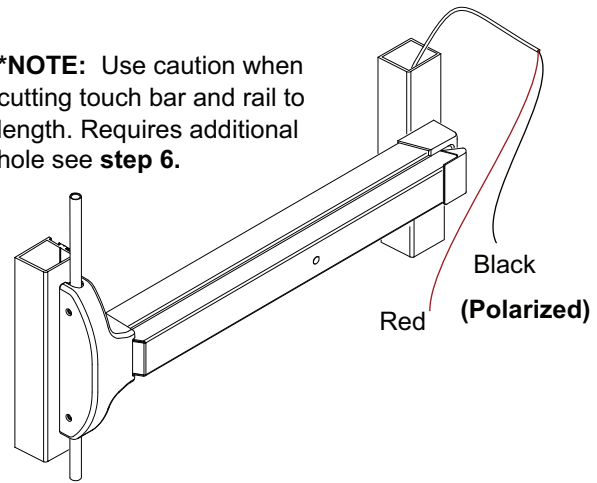

Option: "MS" Monitor Switch: Monitors movement of touch bar, or can be used to signal an external light, horn etc.

Located on the rear arm assembly as shown;
Comes standard with (2) two micro switches.
Both can be wired normally open or normally
closed.

**On the "FL" series it can be added, however
the touch bar must be removed completely
from the rail to install switch assembly.**

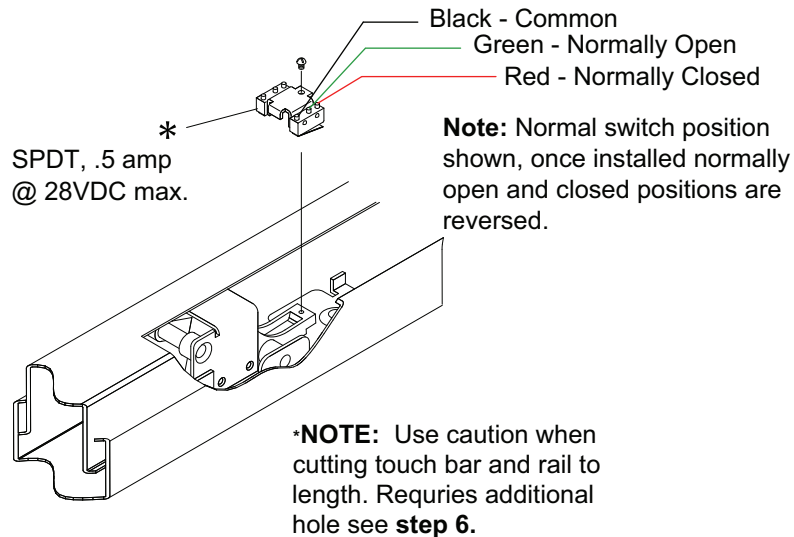

RETROFIT FROM EXISTING AD4400 TO NEW 9800 MODEL

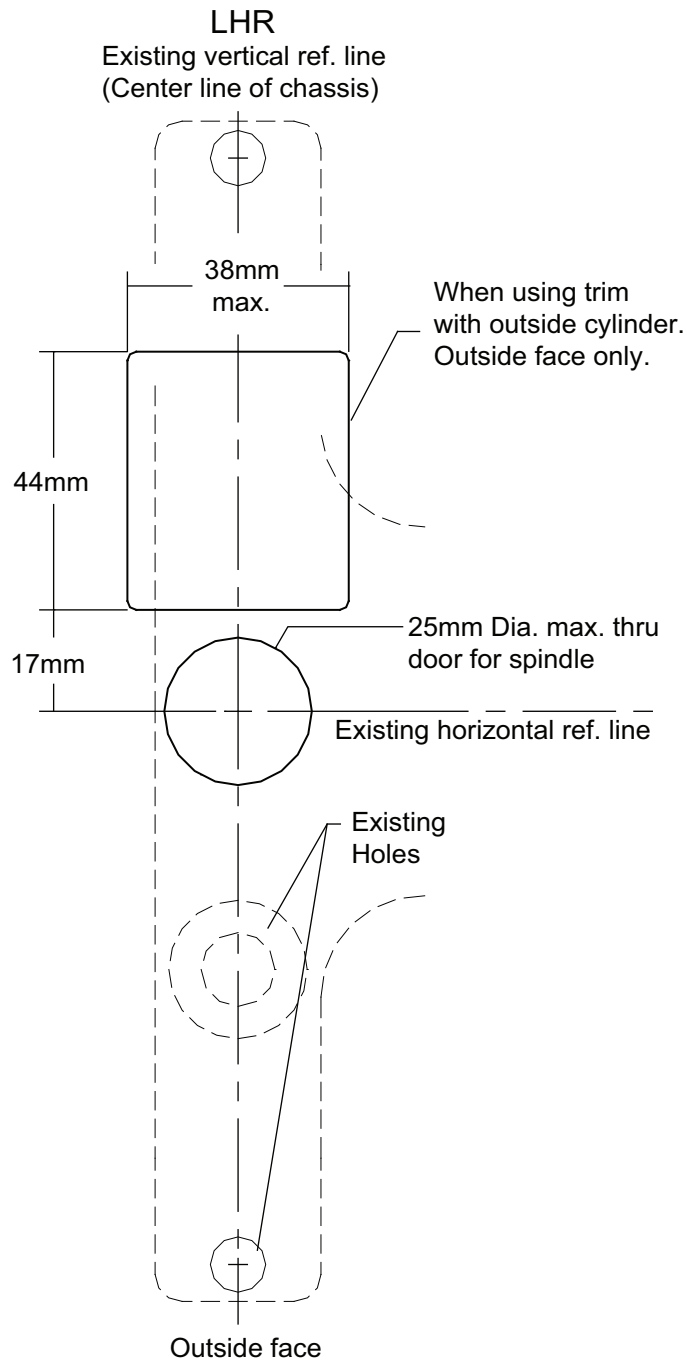

DO NOT SCALE

Additional installation instructions:

New "Z" trim required if trim is being used.

New rods may be required.

Existing strikes may or may not have to be adjusted or relocated and replaced.

Install chassis assembly to door, install end cap bracket to door, hold touch bar and rail assembly in position aligning screw holes in rail with mounting screw location of chassis, mark a line on rear of rail where front edge of end cap bracket is then cut touch bar and rail assembly to length.

Install touch bar and rail to door then install all covers.

BS EN 1125 : 2008 PANIC EXIT DEVICE ON A SINGLE DOOR
ANNEX A

Installation and Fitting Instructions

A.1 The producer shall specify the appropriate fixing arrangement for the door types for which the exit device is designed.

A.2 Before fitting an exit device to a door, the door should be checked to ensure correct hanging and freedom from blinding.

It is not recommended, for example, that exit devices be fitted to hollow core doors unless specially designed by the producer for this type of door.

It is recommended to verify that the door construction allows the use of the device, i.e. to verify that offset hinges and engaging leaves allow both leaves to be opened simultaneously (See A4), or to verify that the gap between door leaves does not differ from that defined by the exit device producer, or to verify that the opening elements do not interfere, etc.

A.3 Before fitting a panic exit device to a fire/smoke resisting door, the fire certification of the fire door assembly on which the exit device has been tested to prove suitability for use on a fire door should be examined. It is of utmost importance that an exit device is not used on a fire door assembly of a greater fire resistance time than approved for. See Annex B.

A.4 Care should be taken to ensure that any seals or weather-stripping fitted to the complete door assembly, do not inhibit the correct operation of the panic exit device.

A.5 On double doorsets with rebated meeting stiles and where both leaves are fitted with panic exit devices, it is essential to check that either leaf will open when its panic exit device is activated and also that both leaves will open freely when both panic exit devices are operated simultaneously.

A.6 Where panic exit devices are manufactured in more than one size, it is important that the correct size is selected.

A.7 Category 2 (Standard projection) panic exit devices should be used in situations where there is restricted width for escape, or where the doors to be fitted with the panic exit devices are not able to open beyond 90°

A.8 Where a panic exit device is designed to be fitted to a glazed door, it is essential that the glazing is tempered or laminated glass.

A.9 Different fixing can be necessary for fitting panic exit devices to wood, metal or frameless glass doors. For more secure fixing, male and female through-door bolts, reinforcement and rivets can be used.

A.10 Panic exit devices are not intended for use on double action (double swing) doors unless specifically designed by the exit device producer.

A.11 The fixing instructions should be carefully followed during installation. These instructions and any maintenance instructions should be passed on by the installer to the user. See Annex C

A.12 The horizontal bar should normally be installed at a height of between 900mm and 1100mm from the finished floor level, when the door is in the secured position. Where it is known that the majority of the users of the premises will be young children, consideration should be given to reducing the height of the operating bar.

A.13 The horizontal bar should be installed so as to provide the maximum effective length.

A.14 The bolt heads and keepers should be fitted to provide secure engagement. Care should be taken to ensure that no projection of the bolt heads, when in the withdrawn position, can prevent the door swinging freely.

BS EN 1125 : 2008 PANIC EXIT DEVICE ON A SINGLE DOOR
ANNEX A continued

Installation and Fitting Instructions

A.15 Where panic exit devices are to be fitted to double door sets with rebated meeting stiles and self closing devices, a door coordinator device in accordance with EN 1158 (See Bibliography) should be fitted to ensure the correct closing sequence of the doors. This recommendation is particularly important with regard to smoke/fire-resisting door assemblies.

A.16 No devices for securing the door in the closed position should be fitted other than specified in this European Standard. This does not preclude the installation of self-closing devices.

A.17 If a door closing device is to be used to return the door to the closed position, care should be taken not to impair the use of the doorway by the young, elderly and infirm.

A.18 Any keepers or protection plates provided should be fitted in order to ensure compliance with this European Standard.

A.19 A sign which reads "Push Bar to open" or a pictogram should be provided on the inside face of the door immediately above the horizontal bar, or on the bar if it has a sufficient flat face to take the size of lettering required. The surface area of the pictogram should be not less than 8000mm² and its colours should be white on a green background. It should be designed such that the arrow points to the operating element, when installed.

ANNEX C

Maintenance Instructions

The following information shall accompany the product:-

A) Inspect and operate the emergency exit device to ensure that all components are in a satisfactory working condition. Using a force gauge, measure and record the operating forces to release the exit device.

B) Ensure the keeper(s) is (are) free from obstruction.

C) Check that the emergency exit device is lubricated in accordance with the producer's instructions.

D) Check that no additional locking devices have been added to the door since its original installation.

E) Check periodically that all components of the system are still correct in accordance with the list of approved components originally supplied with the system.

F) Check periodically that the operating element is correctly tightened and, using a force gauge, measure the operating forces to release the exit device. Check that the operating forces have not changed significantly from the operating forces recorded when originally installed.



- Ø A 1/8" (3 mm)
- B 4.2mm (M5 TAP)

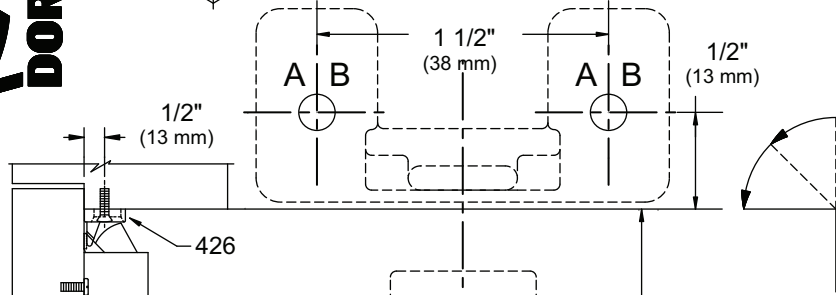

**STANDARD
Top Latch
AD426 Keep**

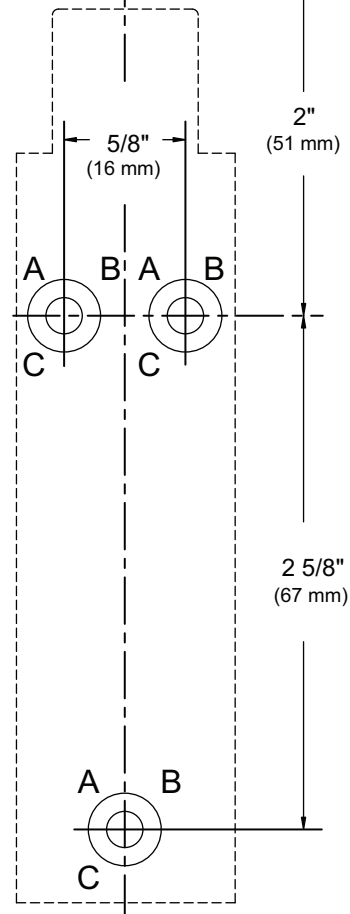

- Ø
- A 1/8" (3 mm)
- B No. 4.2mm (M5 TAP)
- C 3/8" (10 mm)

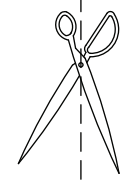
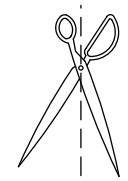

- Ø
- A 1/8" (3 mm)
- B 4.2mm (M5 TAP)
- C 3/8" (10 mm)

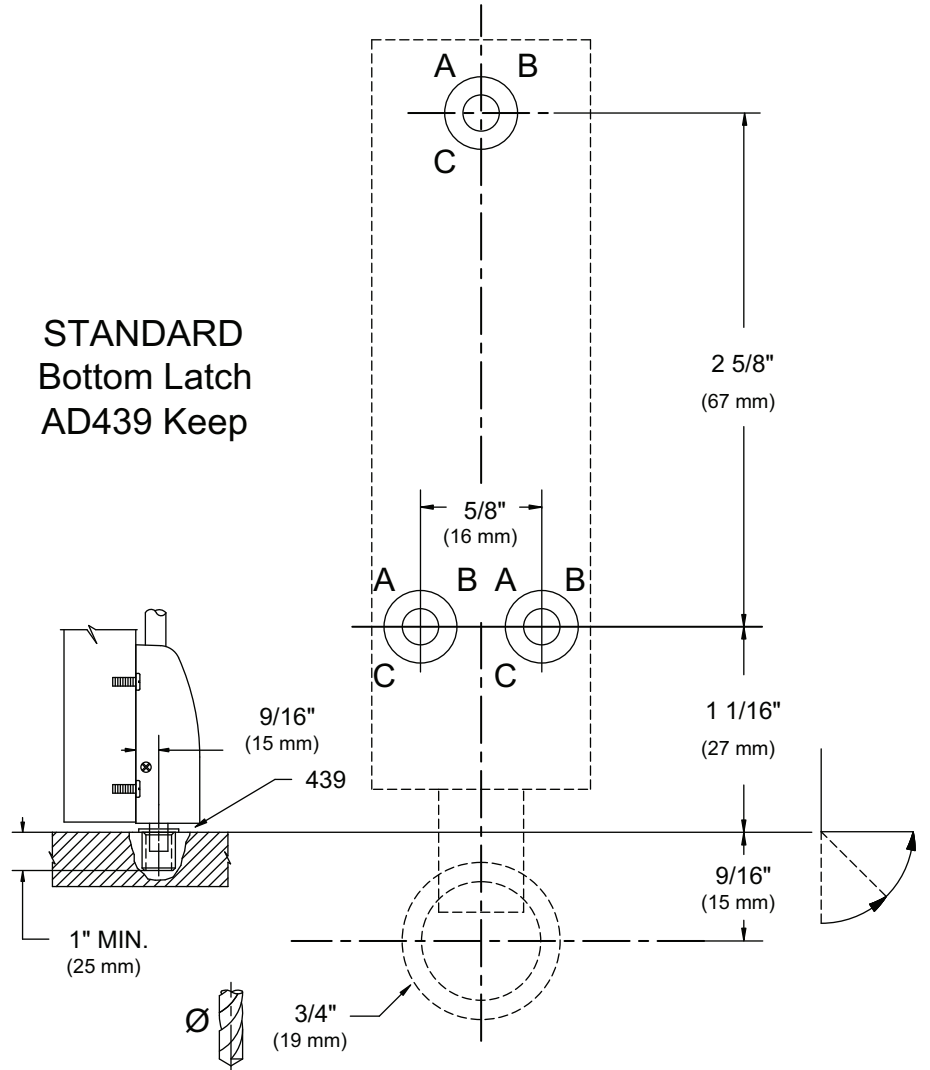

**STANDARD
Bottom Latch
AD439 Keep**

- Ø
- 3/4" (19 mm)

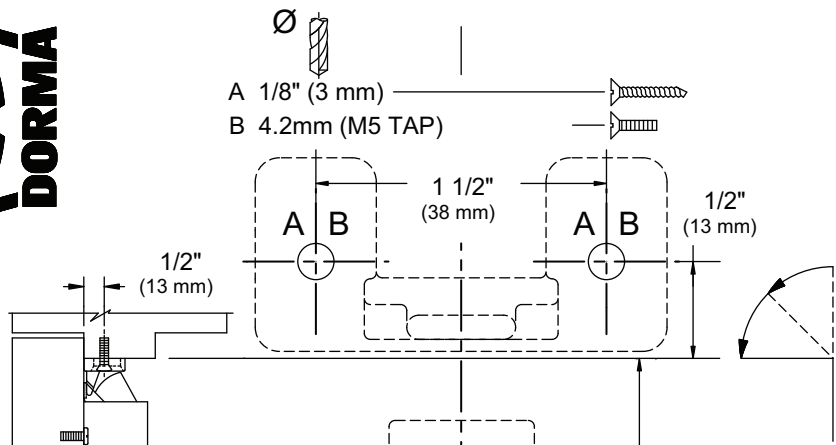

STANDARD
Top Latch
AD426 Keep

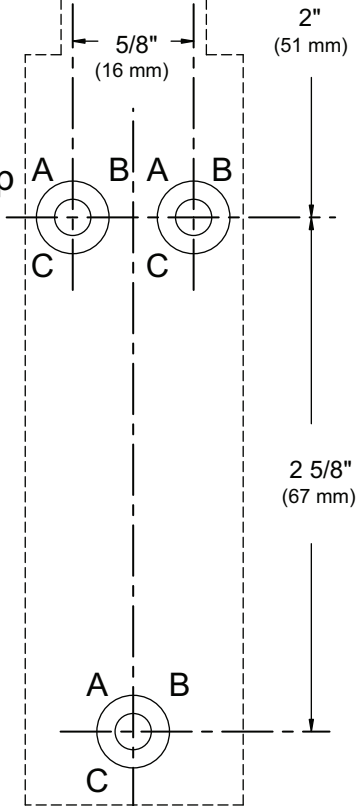

- A 1/8" (3 mm)
- B 4.2mm (M5 TAP)
- C 3/8" (10 mm)

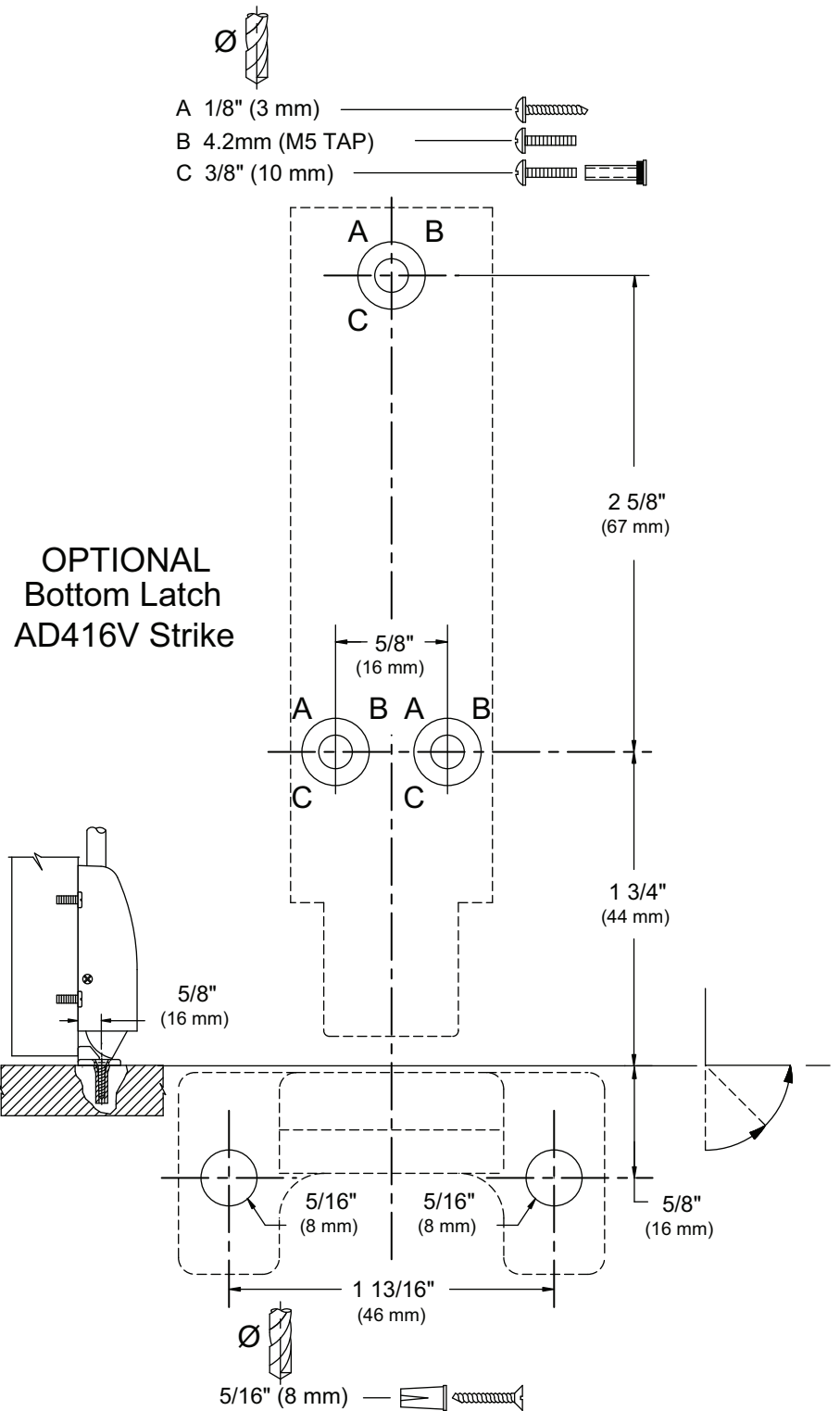
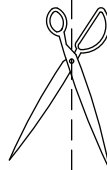
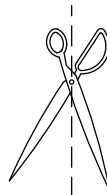

OPTIONAL
Bottom Latch
AD416V Strike

- A 1/8" (3 mm)
- B 4.2mm (M5 TAP)
- C 3/8" (10 mm)

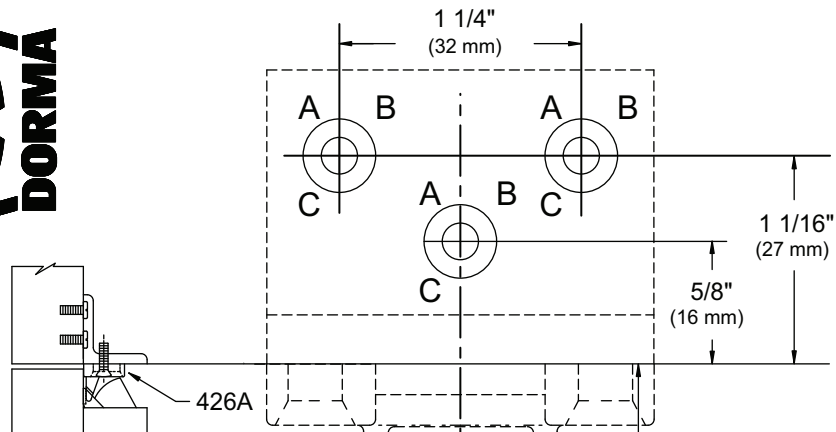

- Ø A 1/8" (3 mm)
- B 4.2mm (M5 TAP)
- C 3/8" (10 mm)

OPTIONAL Top Latch AD426A Keep

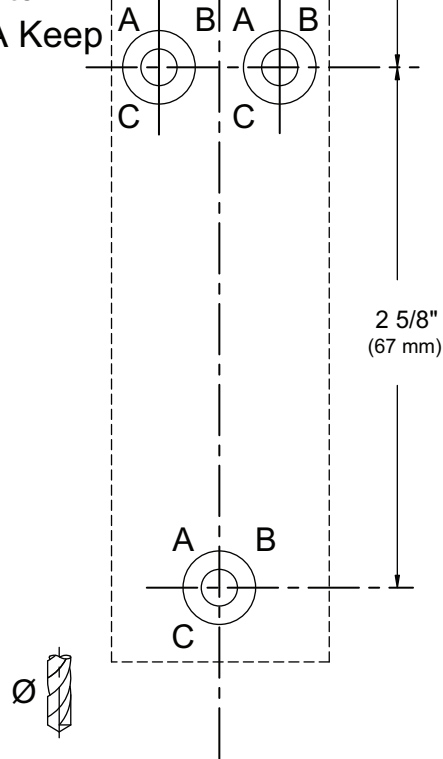

- A 1/8" (3 mm)
- B 4.2mm (M5 TAP)
- C 3/8" (10 mm)

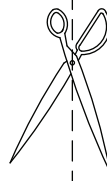

OPTIONAL Bottom Latch AD431 Strike

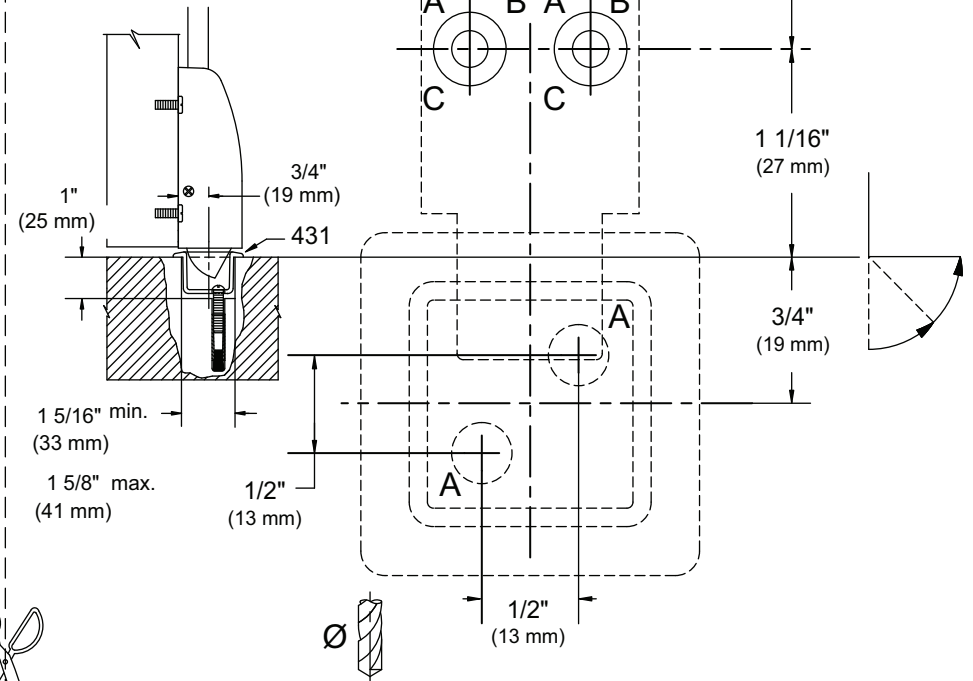

- Ø A 3/8" (10 mm)

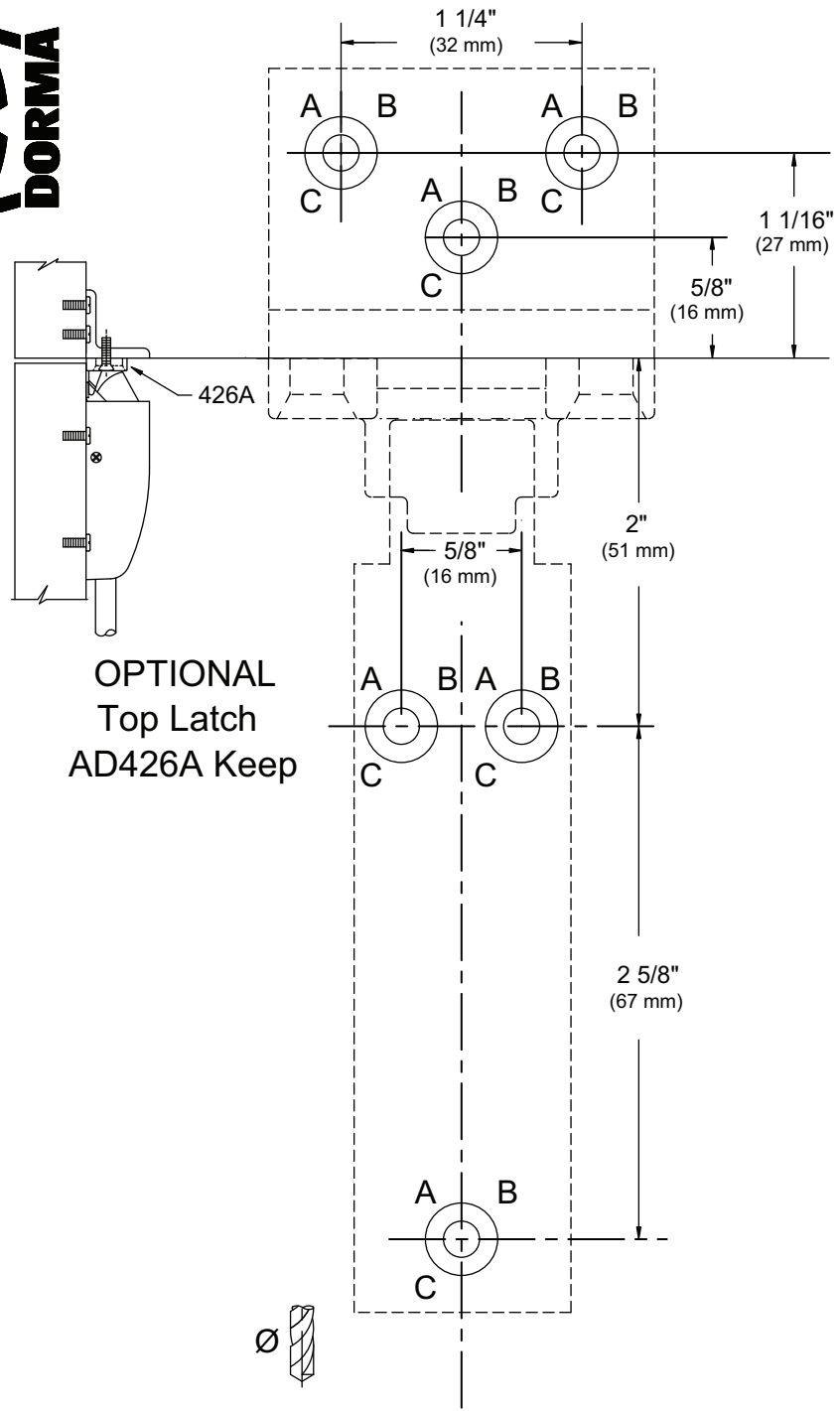

**OPTIONAL
Top Latch
AD426A Keep**

- A 1/8" (3 mm)
- B No. 4.2mm (M5 TAP)
- C 3/8" (10 mm)

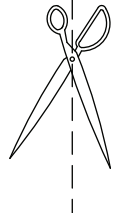
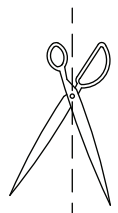

- A 1/8" (3 mm)
- B No. 4.2mm (M5 TAP)
- C 3/8" (10 mm)

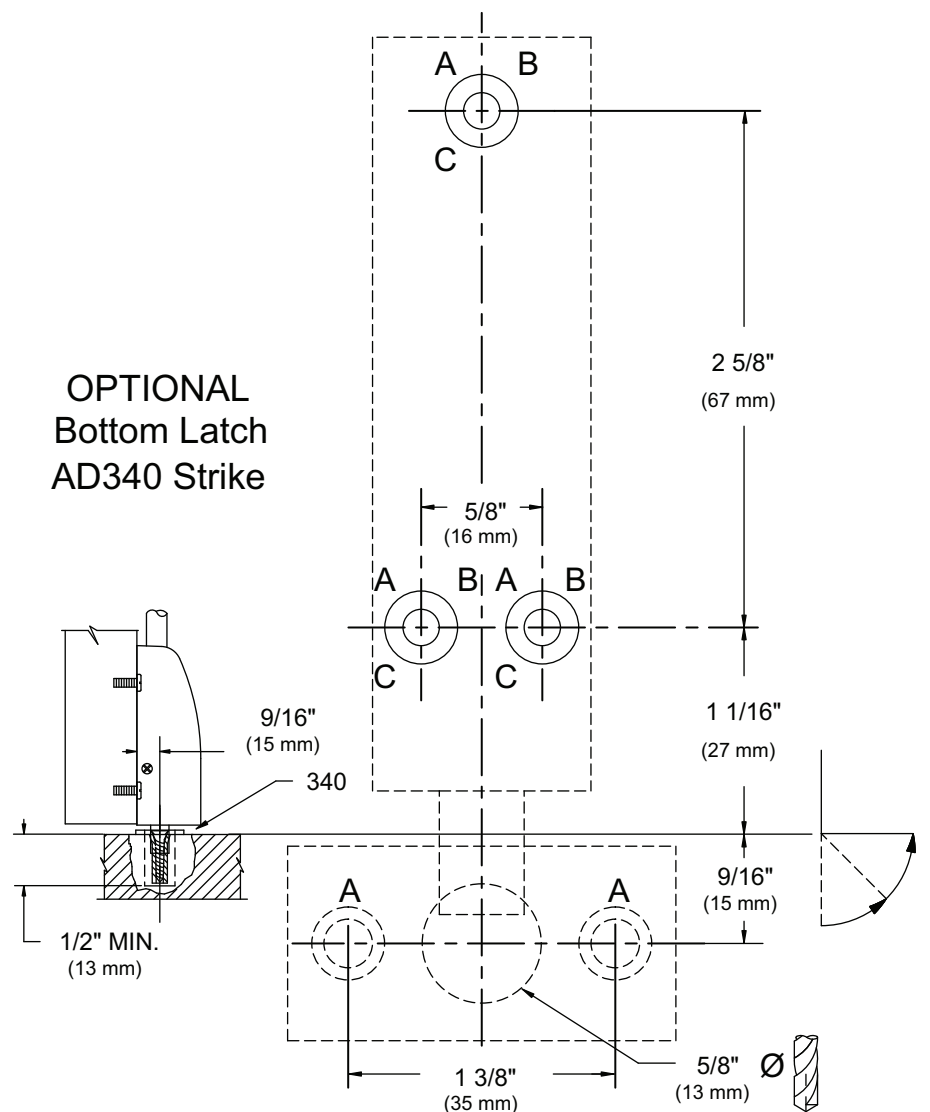

**OPTIONAL
Bottom Latch
AD340 Strike**

- A 5/16" DIA. x 1" DEEP (8 mm x 25 mm)

DORMA 9800FL SURFACE PANIC BOLT

FIXING INSTRUCTIONS

This device is intended for use on single and/ or double outward opening fire escape route doors.

Category of projection = Category 2

Field of door application = Category A

Maximum of 5mm door distortion allowed to ensure safe exit.

Maximum of a 1000N pulling force achieved against the fixing screws.

This device is suitable for use on fire doors.

60 min. single and double timber doors.

240 min. single and double steel doors.

WARNING

The safety features of this product are essential to its compliance with EN 1125 (2008). No modification of any kind, other than those described in these instructions, is permitted.

Panic devices manufactured in accordance with EN 1125 : (2008) will provide a high degree of safety and reasonable security provided they are fitted to doors and frames of equal quality and in good condition. The doors must be correctly hung and free from binding or any distortion. This device is not recommended for wood hollow core doors.

IMPORTANT

This equipment must be installed by a competent fitter. If these fixing instructions are not followed, then no responsibility for malfunction will be accepted by the manufacturer, and warranty claims may be considered invalid.

These fixing instructions must be passed to the user after installation has been completed.

EN 1125 CLASSIFICATION NUMBER FOR THIS PRODUCT

3	7	6	B	1	3	2	2	B	A
---	---	---	---	---	---	---	---	---	---

DOOR SIZES

This product is suitable for doors up to

Size A 838mm to 1220mm wide, 2500mm high.

Size B 686mm to 915mm wide, 2500mm high.

Size C 610mm to 915mm wide, 2500mm high.

(Doors above 2500mm fall outside the scope of EN 1125)

200Kg door mass maximum.

LHRB

VERTICAL REF. LINE
(CENTERLINE OF CHASSIS)

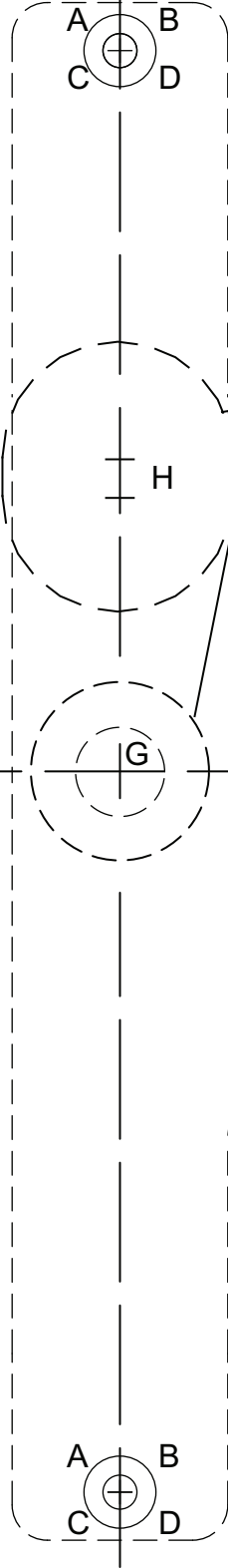

RHRB

VERTICAL REF. LINE
(CENTERLINE OF CHASSIS)

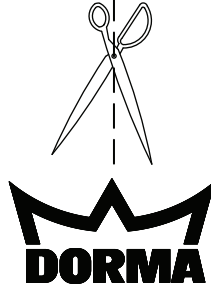
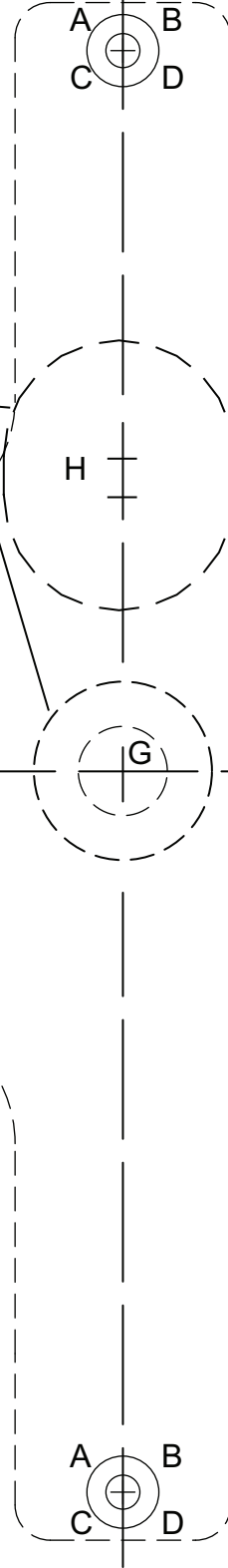

EXIT DEVICE 9800"FL" SERIES

OUTSIDE
FACE ONLY

OUTSIDE
FACE ONLY

NOTE: FOR CYLINDER ONLY
FUNCTION SEE PAGE 5

HORIZONTAL REFERENCE LINE

- A FOR TIMBER DOOR 3.8 x 25mm DEEP
- B FOR METAL DOOR 4.2 x M5 TAP
- C FOR SEX BOLT 10mm DIA. HOLE THRU DOOR
- D FOR USE WITH TRIM 10mm DIA. HOLE THRU DOOR
- G FOR KNOB/LEVER/THUMBTURN 25mm DIA. OUTSIDE FACE
13mm DIA. INSIDE FACE
- H FOR KNOB/LEVER/THUMBTURN 25mm DIA. OUTSIDE FACE
38mm DIA. x 44 HIGH FOR CYLINDER CLEARANCE